

3-Inch 9300 Series Discharge Valve



A UTC Fire & Security Company

P/N: 93-170000-000

F-93-9046

FEATURES

- Large Capacity Agent Flow
- Grooved Fitting Connection
- FM Approved
- UL Listed

DESCRIPTION

The 3-inch 9300 series valve is designed to discharge FM-200® clean agent. The 3-inch valve is installed on the 600 lb. and 900 lb. FM-200 cylinders, to facilitate high capacity discharge flow from these cylinders. The pressure relief device for the 3-inch valve is located on the cylinder head.

OPERATION

The 3-inch 9300 series valve can be operated by all existing Fenwal control heads, except the 48650001 electric control head. The 48650001 control head does not have the capability of operating the 3-inch valve and must not be used on this component.

Actuation of the control head displaces the valve piston and agent (in the form of compressed liquid) is allowed to flow through the discharge port of the valve.

INSTALLATION

The valve must be installed in the cylinder neck ring prior to cylinder filling. Upon assembly of the valve and siphon tube arrangement the valve should be torqued to 50-55 Ft-lb. (68-74.5N-m).

ORDERING INFORMATION

The 3-inch valve can be purchased as a separate component to replace existing valves on new style 600 lb. cylinders (sold after 8/01) and 900 lb. cylinders. The part number for the valve is 93-170000-000. Refer to the parts table of this sheet for replacement parts when overhauling the cylinder valve.



SPECIFICATION

Valve body:	Brass
Piston:	Brass
Finish:	Natural
Valve seat:	Rubber
Nominal operating pressure:	360 psig at 70°F (2.48 Mpa at 21°C)
Operating temperature range:	32 to 130°F (0 to 54°C)
Weight:	46 lb. (21 kg)
Outlet:	3-inch groove fitting

RECHARGE/REPLACEMENT PARTS

The following components are required to be replaced after the cylinder valve has discharged or if the existing components show signs of damage or wear and tear. Refer to the Design Installation Operation and Maintenance manual for full instructions on valve overhaul and maintenance.

Description	P/N
O-ring, Cap	566102410
O-ring, Piston	566103370
O-ring, Seat	566103400
O-ring, Neck	566103470
Pilot Check Assembly	923066
Back-up Ring	554003400

DIMENSIONS

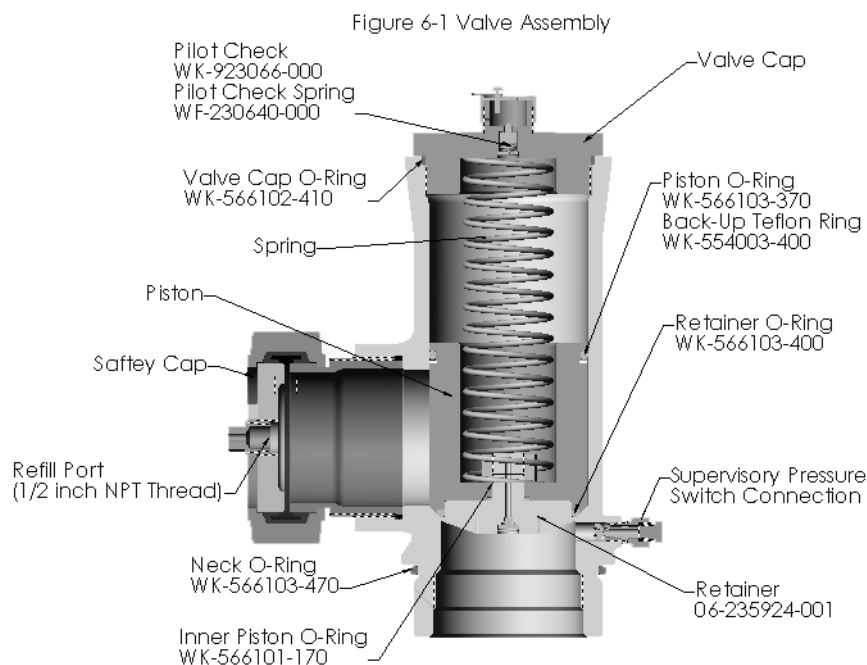

FM-200 is a Registered Trademark of Great Lakes Chemical Corporation.

This literature is provided for informational purposes only. KIDDE-FENWAL, INC. assumes no responsibility for the product's suitability for a particular application. The product must be properly applied to work correctly. If you need more information on this product, or if you have a particular problem or question, contact KIDDE-FENWAL, INC., Ashland, MA 01721. Telephone: (508) 881-2000.



A UTC Fire & Security Company

400 Main Street
Ashland, MA 01721
Ph: 508.881.2000
Fax: 508.881.8920
www.fenwalfire.com