

DS-SD Addressable SmartOne[®] Photoelectric Duct Detector



FOR KIDDE FIRE SYSTEMS INTELLIGENT CONTROL UNITS

Effective: May 2018
K-76-103

FEATURES

- *Photoelectric Based Duct Detector*
- *UL, ULC, FM listed*
- *Alarm Sensitivity 1.3% to 2.2%/ft obscuration*
- *Works with SmartOne[®] communications protocol*
- *Compatible with Kidde[®], Fenwal[®] and Chemetron[®] branded intelligent control units*
- *Operates in conjunction with legacy SmartOne devices*
- *Supports Remote Alarm LED*
- *Integrated design of the photoelectric detector within the duct housing*
- *Less than 2" deep for easy installation*
- *Air velocity rating 100 to 4,000 ft/min*
- *Electronic addressing performed with SmartOne handheld programmer*

DESCRIPTION

The Model DS-SD Duct Smoke Detector detects the presence of smoke under extended temperature ranges in a building's HVAC system. Its primary purpose is to provide early warning of the presence of smoke in the duct. It is typically used to detect smoke in the supply side of the HVAC system, but can provide supervision of the return side as well.

The Model DS-SD detector is comprised of a plastic housing, a printed circuit board, a clear plastic cover, and an exhaust tube. The clear plastic cover permits visual inspections without having to disassemble the detector. The cover attaches to the detector housing using four captive screws and forms an airtight chamber around the sensing electronics. A sampling tube is required to introduce air into the duct smoke detector. The sampling tube is ordered separately and varies in length depending on the width of the HVAC duct.

The DS-SD Addressable Duct Detector operates on all Kidde Fire Systems addressable fire alarm-suppression control units (Kidde, Fenwal and Chemetron brands) employing SmartOne communications protocol and can be mixed in any order with any current and legacy SmartOne detectors.

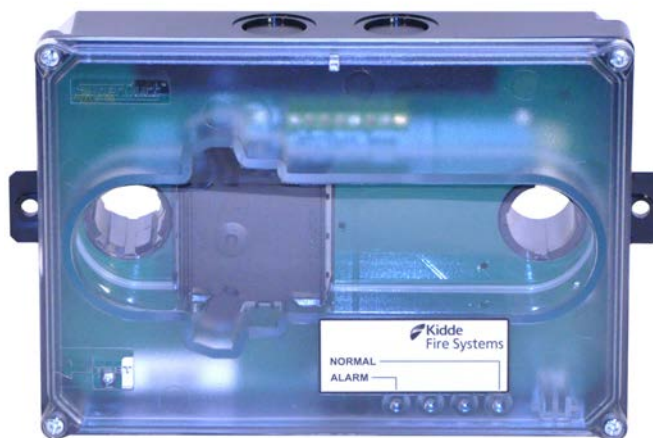

PART NUMBERS

Model	Description	Model	Description
DS-SD	Addressable Duct Detector, SmartOne	SD-T78	78-inch sampling tube
SD-T8	8-inch sample tube	SD-T120	120-inch sampling tube
SD-T18	18-inch sampling tube	SD-PH	Protective housing for high humidity areas
SD-T24	24-inch sampling tube	SIGA-LED	Remote LED indicator
SD-T36	36-inch sampling tube	SD-VTK	Air velocity test kit
SD-T42	42-inch sampling tube	SD-GSK	Cover gasket kit
SD-T60	60-inch sampling tube		

LEDS

Control or Indicator	Description
Alarm LED	Flashes (red) when the detector is in Alarm State
Normal LED	Flashes (green) during normal operation

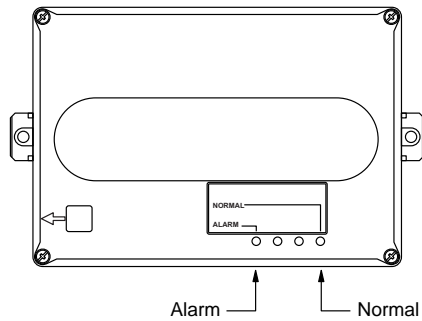

TYPICAL INSTALLATION

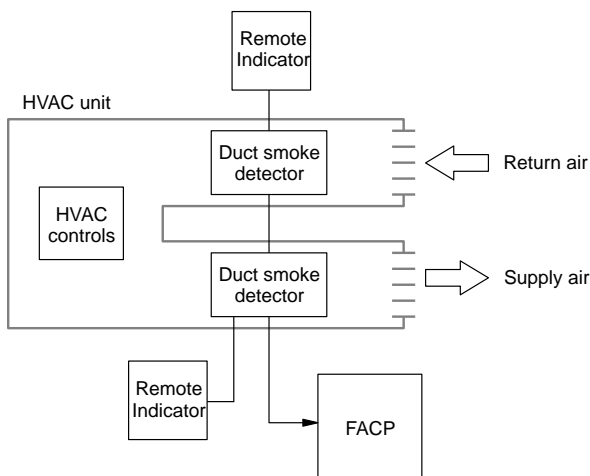

TYPICAL WIRING

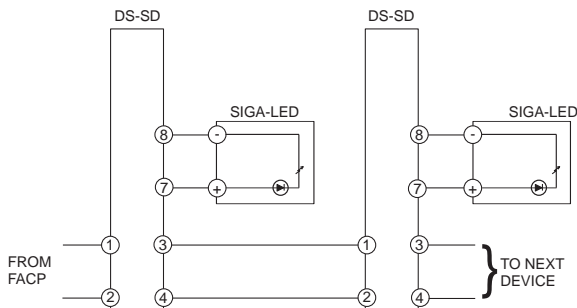

TECHNICAL SPECIFICATIONS

Dimensions	8.70 x 5.45 x 1.90 in (220.98 x 138.43 x 48.26 mm)
Wire size	14 to 22 AWG
Smoke detection method	Photoelectric (light scattering principle)
Air velocity rating	100 to 4000 ft/min (30.5 to 1219.2 m/min)
Air pressure differential	0.005 to 1.00 in. of water (0.127 to 25.4 mm of water)
Alarm Sensitivity (fixed)	1.3% to 2.2%/ft obscuration (4.26% to 7.22%/m obscuration)
Pre-Alarm Sensitivity	Pre-alarm will occur at 75% of the alarm point
LED indicators	Alarm (red), Normal (green)
Detector operating voltage	24 Vdc Nominal
Detector operating current	Normal 150 μ A Alarm 220 μ A
Operating environment temperature	32 to 120 ° F (0 to 49 ° C)
Humidity	93% RH, non-condensing
Agency Listing	UL, ULC, FM

COMPATIBLE CONTROL UNITS

Kidde	ARIES NETLink
Kidde	ARIES
Kidde	PEGAsys *
Fenwal	FenwalNET 8000-ML
Fenwal	FenwalNET 6000
Fenwal	FenwalNET 2000 *
Chemetron	MICRO MLX
Chemetron	MICRO SLX

* DS Series detectors are compatible with FenwalNET 2000 and PEGAsys control units running software version 82.4. Note that FenwalNET 2000 and PEGAsys control units are no longer UL Listed or FM Approved. DS Series detectors have not been compatibility-tested on legacy control units older than FenwalNET 2000 and PEGAsys.

EXPLODED VIEW

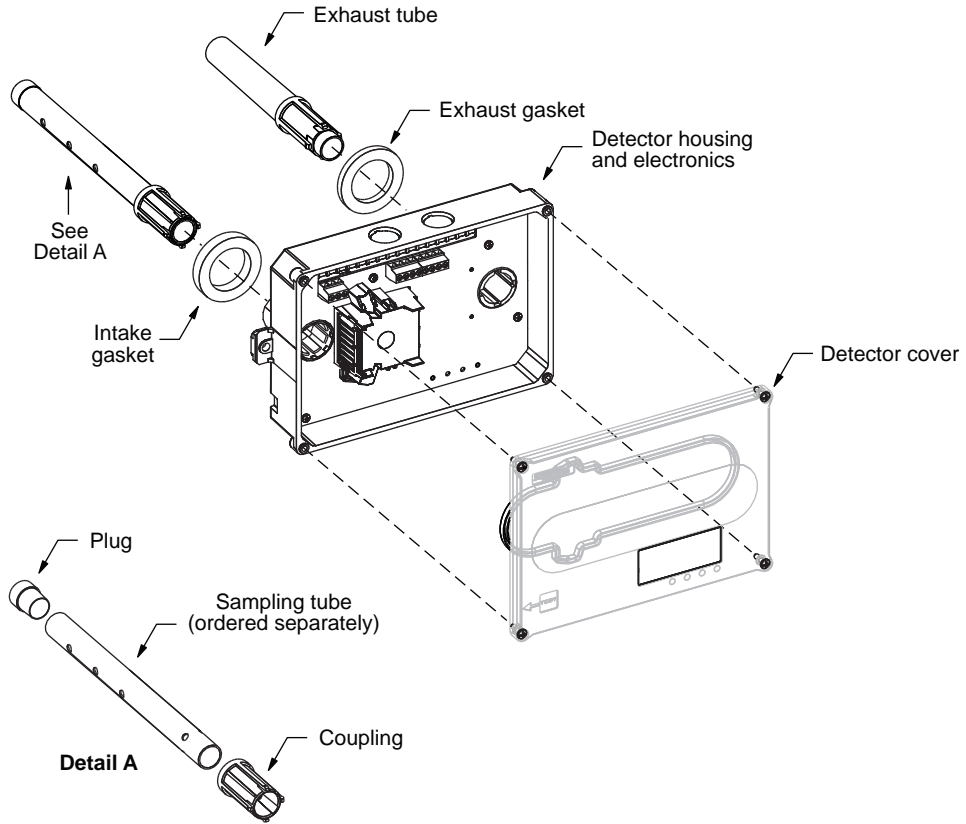

SIDE VIEW

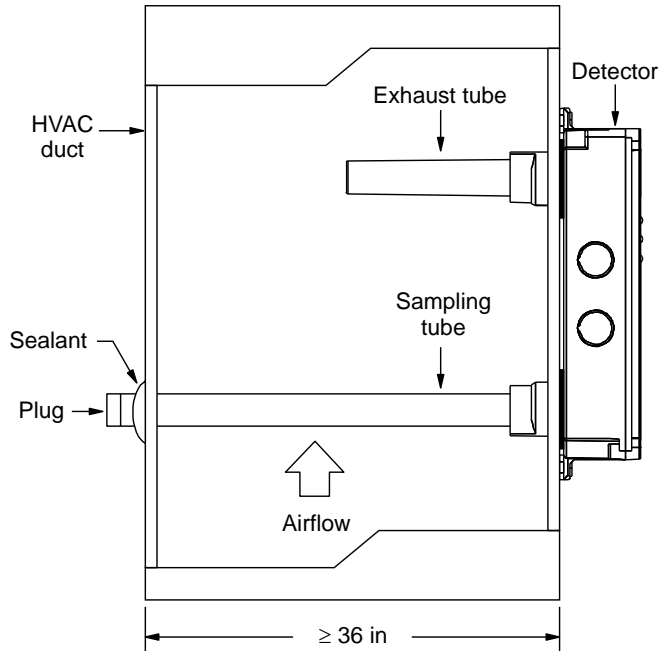

DIMENSIONS

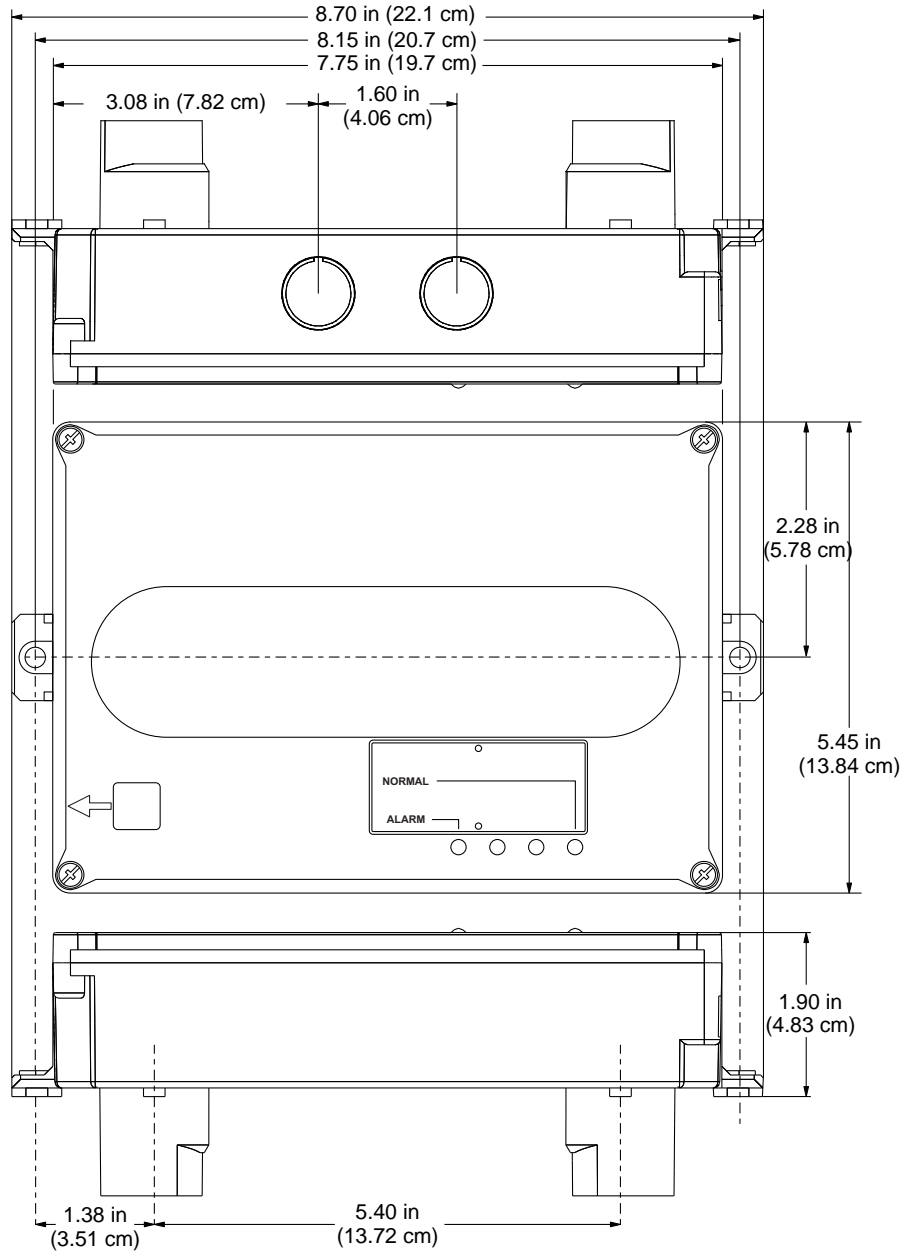

EXPORT INFORMATION (USA)

Jurisdiction: EAR

Classification: EAR99

This document contains technical data subject to the EAR.

Kidde, Fenwal, Chemetron and SmartOne are registered trademarks of Kidde-Fenwal, Inc., or its parents, subsidiaries or affiliates.

This literature is provided for informational purposes only. KIDDE-FENWAL, INC. believes this data to be accurate, but it is published and presented without any guarantee or warranty whatsoever. KIDDE-FENWAL, INC. assumes no responsibility for the product's suitability for a particular application. The fire suppression system design, installation, maintenance, service and troubleshooting must be performed by trained, authorized Kidde Fire Systems distributors for the product to work correctly. If you need more information on this product, or if you have a particular problem or question, contact: KIDDE-FENWAL, INC., Ashland, MA 01721 USA, Telephone: (508) 881-2000.