

# Series 27100, 28000

Vertical DETECT-A-FIRE® Units

Installation Instructions

12.01.D

# FENWAL®

## DESCRIPTION

DETECT-A-FIRE® thermal detectors are UL Listed, UL of Canada available upon request, and FM Approved detection and release devices used with fire detection systems to activate alarms and actuate extinguishing systems. This Rate Compensated device combines the best features of both fixed temperature and rate-of-rise detectors.

## ELECTRICAL RATING

Model Number	Contact Operation on Temperature Rise	Electrical Rating* (Resistive Only)
27120	Opens (450° F Max.)	5.0 Amps 125 VAC 0.5 Amps 125 VDC
28020		
27121	Closes	5.0 Amps 125 VAC 0.5 Amps 125 VDC 2.0 Amps 24 VDC 1.0 Amps 48 VDC
28021		

\*Although incandescent lamps are considered resistive, their inrush current is 10 - 15 times their steady current. Do not exceed ratings.

## LOCATION

DETECT-A-FIRE detectors are precision temperature sensors. They must be mounted in an area (normally a ceiling) so that:

1. The detector spacing complies with both system requirements and requirements of the agency having local jurisdiction.
2. The thermal air path to the shell is not obstructed.

Spacing per UL, FM, and UL of Canada is shown in Table 1. Distances given are for between units on smooth ceilings. Distances from partitions or walls are half that shown. To assure that all spacing requirements are met, consult the authority having local jurisdiction.

## MOUNTING

Detect-A-Fire units are not position sensitive. Horizontal and vertical detectors refer to the most common mounting configuration for that unit. However, each type can be mounted either horizontally or vertically depending on the application and installation requirements.

Table 1

°F Setting	°F Tolerance	SPACINGS (in feet)			Color Coding
		UL	ULC	FM	
140	+7/-8	50	50	25	Black
160	+7/-8	25	25	25	Black
190	+7/-8	50	50	25	White
210	+7/-8	25	50	25	White
225	+7/-8	25	50	25	White
275	±10	25	50	25	Blue
325	±10	50	50	25	Red
360	±10	25	50	25	Red
450	±15	25	50	25	Green
500	±15	50	50	25	Orange
600	±20	N/A	50	25	Orange
725	±25	N/A	50	25	Orange

**Note:** For clean agents and CO<sub>2</sub> suppression systems, ceiling spacing 20 ft. (6.1 meters) apart unless otherwise specified.

Not all units are suitable for all hazard location applications. Refer to Table 2 and markings on the detector for hazardous location suitability.

Table 2

Hazardous Location	Model Number	Fitting Required For UL, ULC Listings and FM Approval
Class I*, Groups A, B, C and D; Class II*, Groups E, F and G	27120-22 27121-20 28020-3 28021-5	Mount detector to a suitably-listed fitting in accordance with National Electric Code and/or local authority having jurisdiction.
Class I*, Groups B, C and D; Class II*, Groups E, F and G	27120-0 27121-0 28021-0	

\*Division 1 and 2.

## INSTALLATION

Series 27120 and 27121

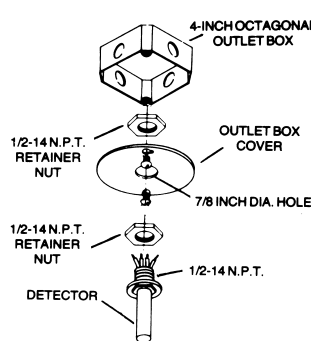

Figure 1

Series 28020 and 28021

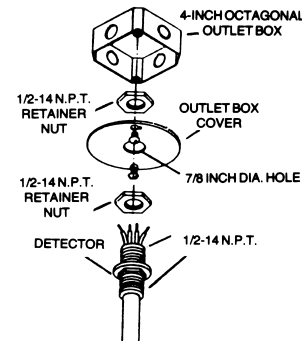

Figure 2

1. Kidde-Fenwal recommends that standard 4-inch octagonal outlet boxes be used to mount detectors.
2. Attach detector to outlet box cover through a 0.875 inch diameter hole and using two 1/2-14NPT retainer nuts as indicated.
3. Connect system wiring to detector per Figure 3 and applicable electrical codes.
4. Ordinary Locations: The DETECT-A-FIRE Units are to be installed in grounded metallic junction boxes only. They are to be secured to the boxes using two lock nuts, one on either side of the mounting plate. DETECT-A-FIRE Units are not to be installed in non-metallic junction boxes.
5. Hazardous Locations: For Class I, Division 1 and 2 locations install the DETECT-A-FIRE Unit in a listed explosion-proof enclosure with a minimum thread engagement of five full turns. No non-conductive material is to be placed on the threaded joint of the DETECT-A-FIRE Unit or in the listed explosion-proof enclosure. For Division 2 locations assure that a protective ground terminal is provided in the listed explosion-proof enclosure when flexible metal conduit is used.
6. Non-Hazardous Outdoor Locations: Mount the DETECT-A-FIRE in a Listed NEMA Type 3 outlet box, cover and conduit, with 1/2 - 14 NPT threads and a minimum thread engagement of 5 full turns. Use of pipe plugs with RTV silicone rubber sealant, a rubber gasket and self-sealing screws to attach the cover, and PTFE thread seal tape on the DETECT-A FIRE threads should be appropriate for outdoor applications and in accordance with the National Electric Code and/or local authority have jurisdiction.
7. Do not exceed a maximum torque without thread lubricant of 20 foot-pounds (27.1 Newton Meters).

Series 28000 units are similar to Series 27100 units except they have two 1/2-14 NPT threads for mounting.

The unit may be mounted as described above or may be threaded into a 1/2-14 NPT tapped hole in the vessel wall or threaded into a coupling brazed or welded to the vessel wall.

### Field Wiring Requirement

Field wiring must be capable of withstanding the maximum anticipated ambient temperature in the application.

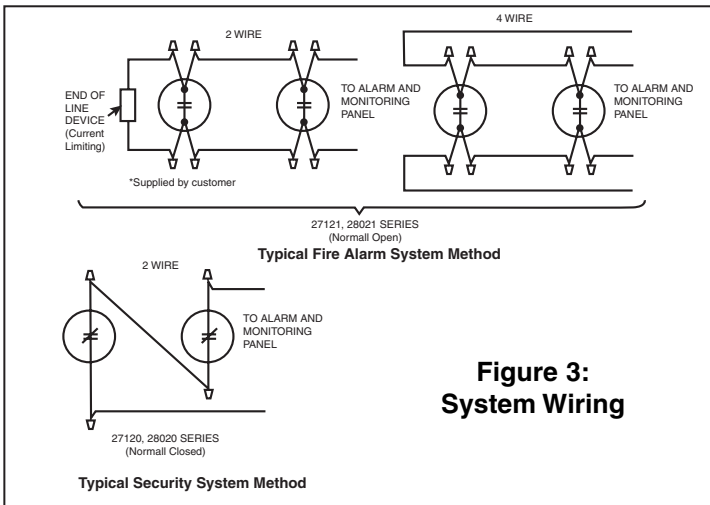
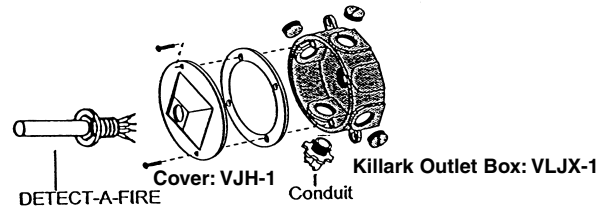

**Figure 3:  
System Wiring**

These instructions do not purport to cover all the details or variations on the equipment described, nor do they provide for every possible contingency to be met in connection with installation, operation and maintenance. All specifications subject to change without notice. Should further information be desired or should particular problems arise which are not covered sufficiently for the purchaser's purposes, the matter should be referred to KIDDE-FENWAL, Inc., Ashland, Massachusetts.

If you need more information on this product, or if you have a question, contact KIDDE-FENWAL, INC., Ashland, MA 01721. (508) 881-2000.

**Figure 4**



**Table 3**

Non-Hazardous Outdoor Locations		
Model Number	° F Temperature Settings	Fittings Required for UL Listings and FM Approval
27120-0 27120-22 27121-0 27121-20	140, 160, 190, 225	Mount detector to a fitting suitable for outside use, (NEMA Type 3), in accordance with National Electric Code and/or local authority having jurisdiction.

### FUNCTIONAL TEST

When used with automatic fire extinguishing systems first disconnect the initiator/solenoid leads from the panel and connect a 24 VDC bulb to initiator terminals in the control unit. Heat the D-A-F units with a heat lamp or other convenient source. When the bulb in the control unit changes state, remove heat source and allow D-A-F unit to cool. Reset control unit. Test lamp must change state and stay changed after system is reset. Do not reconnect initiator/ solenoid leads until all D-A-F units have cooled below set point as indicated by test lamp. When D-A-F units are used in other types of systems, disconnect them from the system, connect a 24 VDC lamp and power source in series with the D-A-F units and test with heat source as above. Make sure that contacts have reset to normal condition before reconnecting to system circuit.

### ⚠ WARNINGS

1. In order to function properly, the sensing shell of the unit must remain free from paint, grease, oil, etc. Should such a build up occur, do not, **under any circumstances**, attempt to remove it. Replace the unit.
2. Detectors mounted in an area subject to physical abuse or damage, other than above, must be suitably protected without obstructing the thermal airpath to the unit.
3. Do not install the unit where the shell would be physically damaged by sand, grain, rocks, etc.
4. Do not overtorque the unit when installing.
5. Any detector that has been abused or damaged must be replaced.
6. Consult the factory for special precautions necessary for outdoor use or moist environments.

ANY OF THE ABOVE COULD CHANGE THE FACTORY TEMPERATURE SETTING, WHICH MAY RESULT IN PROPERTY DAMAGE AND/ OR PERSONAL INJURY OR DEATH.

IT IS POSSIBLE FOR A UNIT TO HAVE BEEN ABUSED OR DAMAGED AND NOT DISPLAY ANY OUTWARD INDICATION OF THE DAMAGE. ALL UNITS SHOULD BE TESTED PERIODICALLY IN ACCORDANCE WITH NATIONAL FIRE PROTECTION ASSOCIATION REQUIREMENTS (72E) OR THE AGENCY HAVING LOCAL JURISDICTION.