

Manifold Check Valves

The manifold check valve is designed to prevent a loss of agent during a discharge in the event that a tank has been removed from the system. The check valve is a “mush-room” type, which lifts into the manifold as discharge occurs.

Two sizes of manifold check valves are available: 1 in. and 2 in.

Manifold are constructed of standard Schedule 40 pipe and 300 lb. fittings. The check valves assemble directly into the fittings.

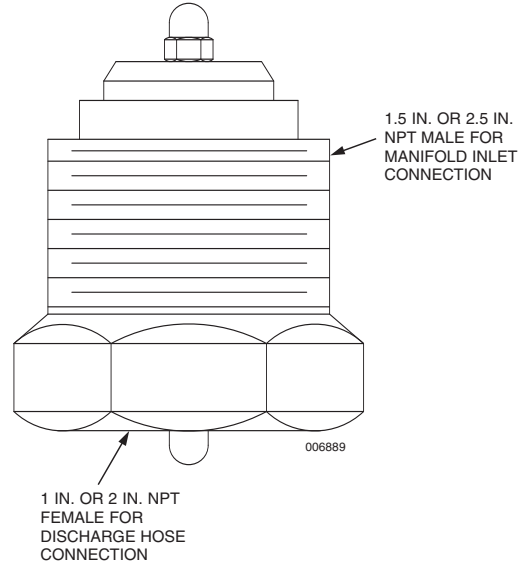

Component	Material	Approvals
Check Valve	Body: Brass Stem and Seal: Stainless Steel	UL Listed ULC Listed FM Approved

Shipping Assembly Part No.	Description
570566	1 in. Manifold Check Valve
570568	2 in. Manifold Check Valve