

## Mounting Bracket Assembly

The mounting bracket assembly consists of a nut, bolt, and two bracket straps (back channel must be supplied by others). Approved type of Unistrut Channel is series P1000T, 1.6 in. x 1.6 in. (41 mm x 41 mm).

Each strap is notched for insertion into the channel, allowing the tank to be properly aligned. The bracket assembly is designed to be mounted to a rigid vertical surface with the tank assembly resting fully on the floor or vertical surface.

A single bracket assembly is required for 20, 50, 90, 140, 280, 390, and 450 lb. tank sizes. Two bracket assemblies are required for the 850 lb. size tank.

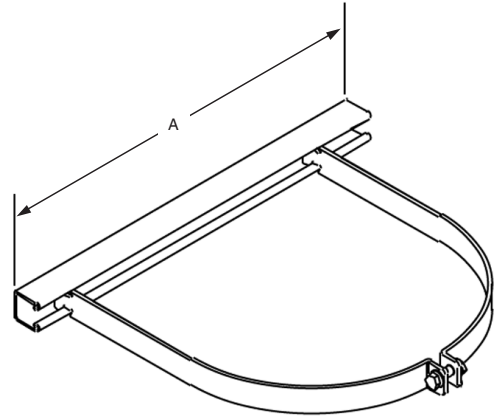

006759

Component	Material	Approvals
Mounting Bracket	Steel	UL Listed ULC Listed FM Approved

Shipping Assembly Part No.	Description	"A" Dimension in. (cm)
570085	Bracket Assembly for 20, 50, and 90 lb. tanks (10 in. diameter)	15.7 (40)
570092	Bracket Assembly for 140, 280, 390, and 450 lb. tanks (16 in. diameter)	23.6 (60)
570336	Bracket Assembly for 850 lb. tank (24 in. diameter)	27.3 (69)