

FM-200[®] Component Description

3-Inch Swing Check Valve



A UTC Fire & Security Company

F-93-9040

FEATURES

- For use with UL Listed & FMRC Approved Systems

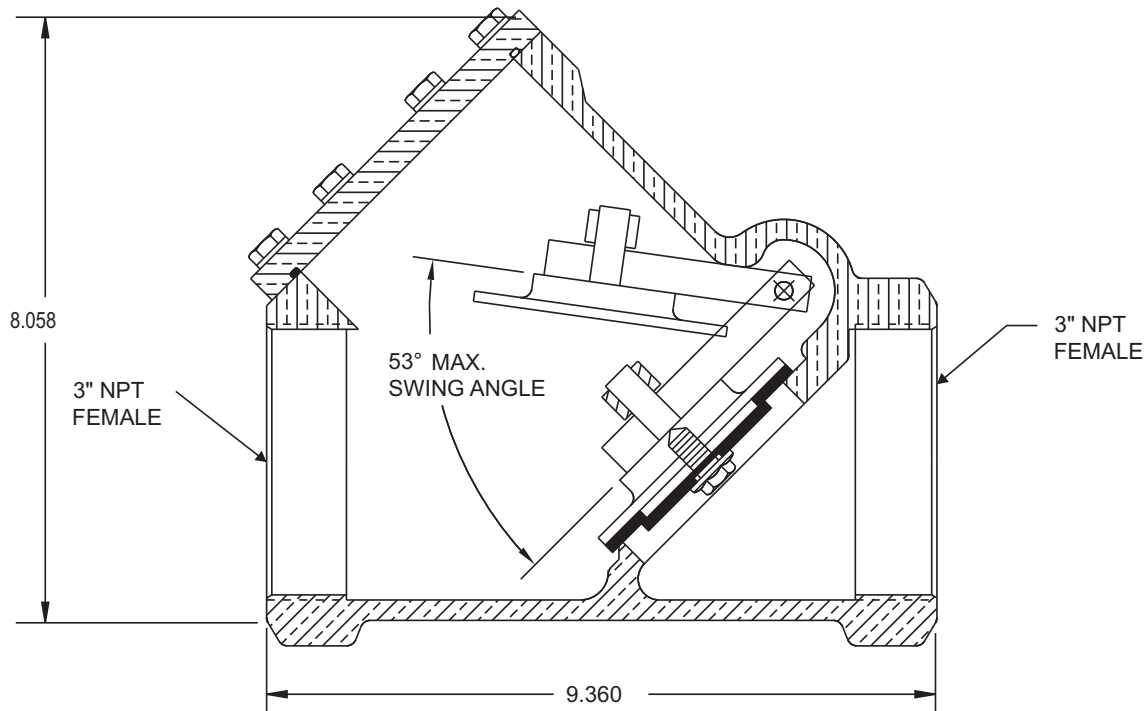

P/N: 06-118058-001

MATERIAL

VALVE BODY & COVER:

BRASS

HEX BOLTS, HINGE, & HINGE PIN:

STAINLESS STEEL

Note: Valve must be installed with arrow pointing in direction of flow.

APPROVALS

- UL Listed
- ULC Listed
- FM Approved

FM-200 is a Registered Trademark of Great Lakes Chemical Corporation.

This literature is provided for informational purposes only. KIDDE-FENWAL, INC. assumes no responsibility for the product's suitability for a particular application. The product must be properly applied to work correctly. If you need more information on this product, or if you have a particular question, contact KIDDE-FENWAL, INC., Ashland, MA 01721. Telephone: (508) 881-2000.

Fenwal Protection Systems
A UTC Fire & Security Company
400 Main Street
Ashland, MA 01721
Ph: 508.881.2000
Fax: 508.881.8920
www.fenwalfire.com