

CO₂ Component Description

Assembly of Grooved Nut Discharge Head to Type "I" Cylinder

Effective: November 2016
K-81-1071 Rev AC

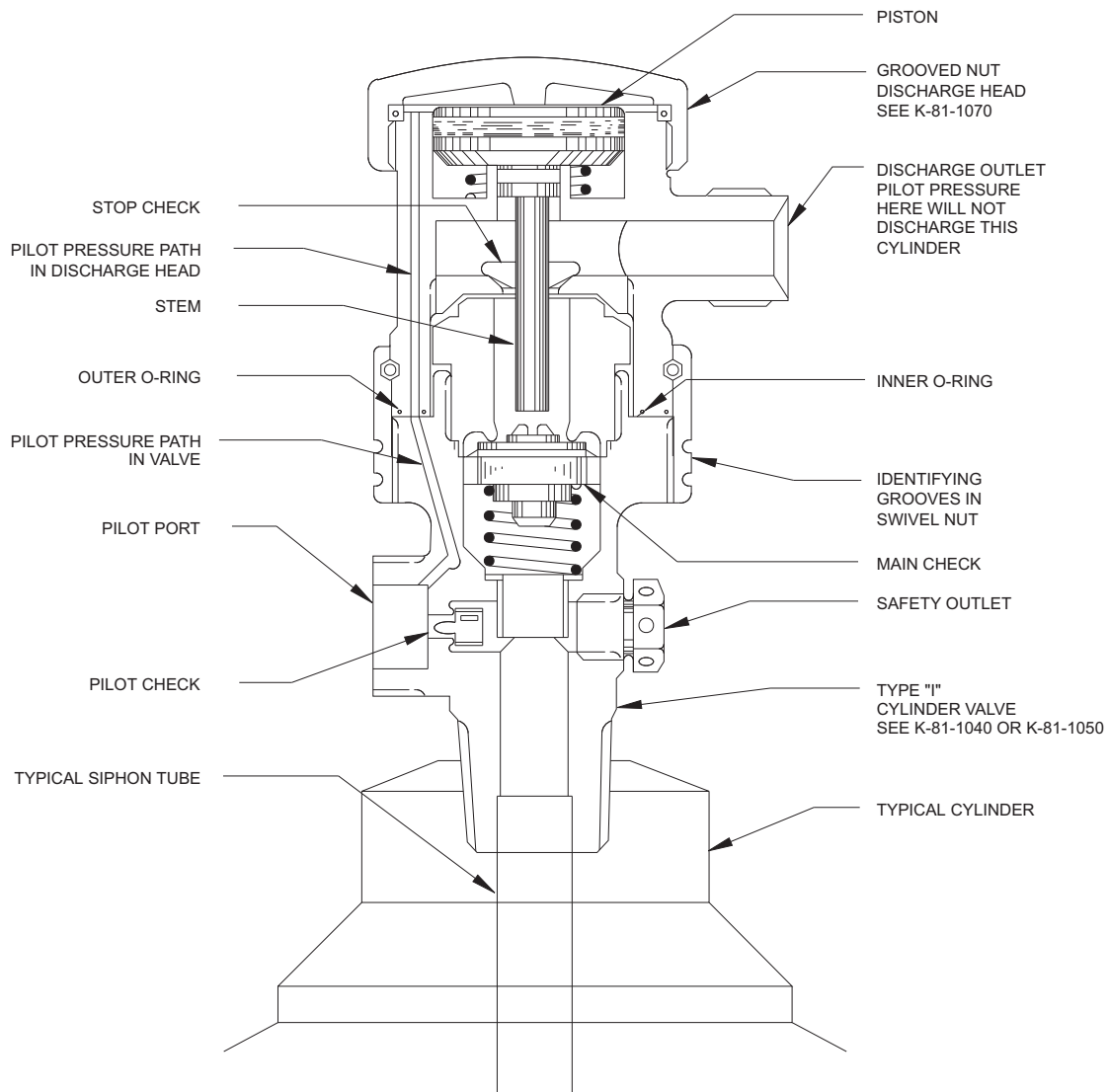

All trademarks are the property of their respective owners.

This literature is provided for informational purposes only. Kidde-Fenwal, Inc. assumes no responsibility for the product's suitability for a particular application. The product must be properly applied to work correctly. The technical data contained herein is limited strictly for informational purposes only. Kidde-Fenwal, Inc. believes this data to be accurate, but it is published and presented without any guarantee or warranty whatsoever. If you need more information on this product, or if you have a particular problem or question, contact Kidde-Fenwal, Inc.

©2016 Kidde-Fenwal, Inc.

EXPORT INFORMATION (USA)
Jurisdiction: EAR
Classification: EAR99
This document contains technical data subject to the EAR.

Kidde Fire Systems
400 Main Street
Ashland, MA 01721 USA
Ph: 508.881.2000
Fax: 508.881.8920
www.kiddefiresystems.com