

CO₂ Component Description

75 lb. and 100 lb. Carbon Dioxide Cylinders

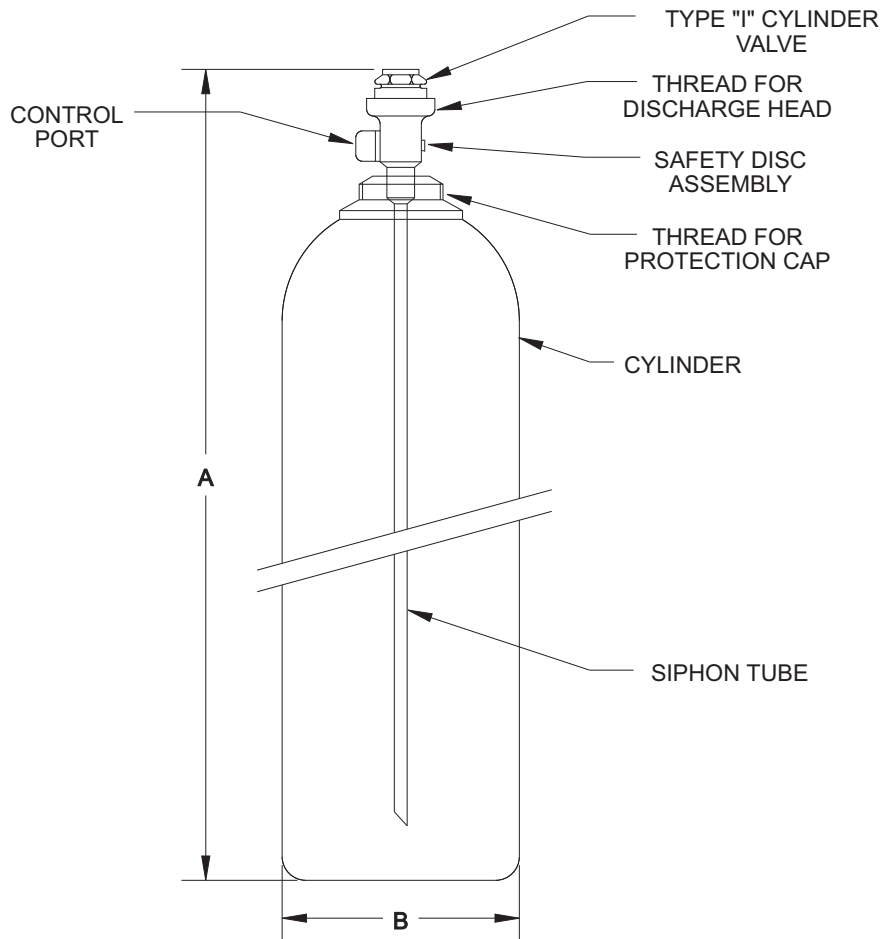

PRESSURE RATING

Service Pressure = 2300 psig

Hydrostatic Test Pressure = 3834 psig

Nominal Pressure = 850 psig @70°F

MATERIALS

Cylinder: Steel

Valve: See K-81-1050 for 5/8 in.

Siphon Tube: Aluminum

FOR ADDITIONAL DATA, SEE K-81-1030

FOR P/N - SEE TABLE

PART NUMBER	CYLINDER	VALVE TYPE	A	B
81-870287-000	75 LB.	5/8 in.	60.0 in.	9.25 in.
81-870269-000	100 LB.		62.0 in.	10.50 in.

All trademarks are the property of their respective owners.

This literature is provided for informational purposes only. Kidde-Fenwal, Inc. assumes no responsibility for the product's suitability for a particular application. The product must be properly applied to work correctly. The technical data contained herein is limited strictly for informational purposes only. Kidde-Fenwal, Inc. believes this data to be accurate, but it is published and presented without any guarantee or warranty whatsoever. If you need more information on this product, or if you have a particular problem or question, contact Kidde-Fenwal, Inc.

EXPORT INFORMATION (USA)

Jurisdiction: EAR

Classification: EAR99

This document contains technical data subject to the EAR.