

# CO<sub>2</sub> Component Description



A UTC Fire & Security Company

## 4-inch Stop (Directional) Valve

Effective: February 2007  
K-81-5150

P/N: 890208

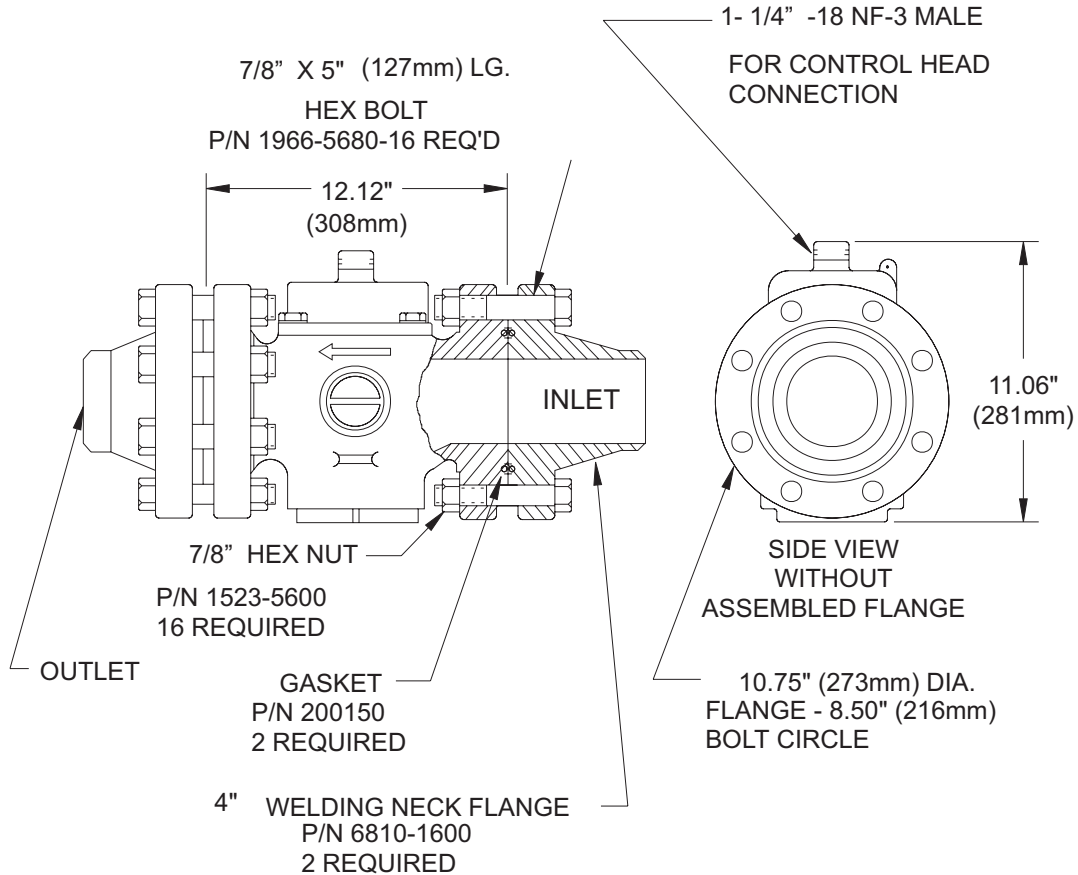

### MATERIALS

VALVE BODY: BRASS

GASKET: IRON

FLANGES, BOLTS, & NUTS: STEEL

**Note:** VALVE MUST BE INSTALLED WITH ARROW  
POINTING IN DIRECTION OF FLOW.

**Operating Pressure (@70°F):** 850 PSI (58 BAR)  
**Test Pressure:** 2250 PSI (155 BAR)  
**Burst Pressure:** 6000 PSI (413 BAR)

This literature is provided for informational purposes only. KIDDE-FENWAL, INC. assumes no responsibility for the product's suitability for a particular application. The product must be properly applied to work correctly. If you need more information on this product, or if you have a particular problem or question, contact KIDDE-FENWAL, INC., Ashland, MA 01721. Telephone: (508) 881-2000.

Kidde Fire Systems  
A UTC Fire & Security Company  
400 Main Street  
Ashland, MA 01721  
Ph: 508.881.2000  
Fax: 508.881.8920  
[www.kiddefiresystems.com](http://www.kiddefiresystems.com)