

CO₂ Component Description

Type "I" Cylinder Valve, 1/2-in.
With Typical Cylinder

WK-P/N: WK-981372-000

Effective: November 2016

K-81-1040 Rev AE

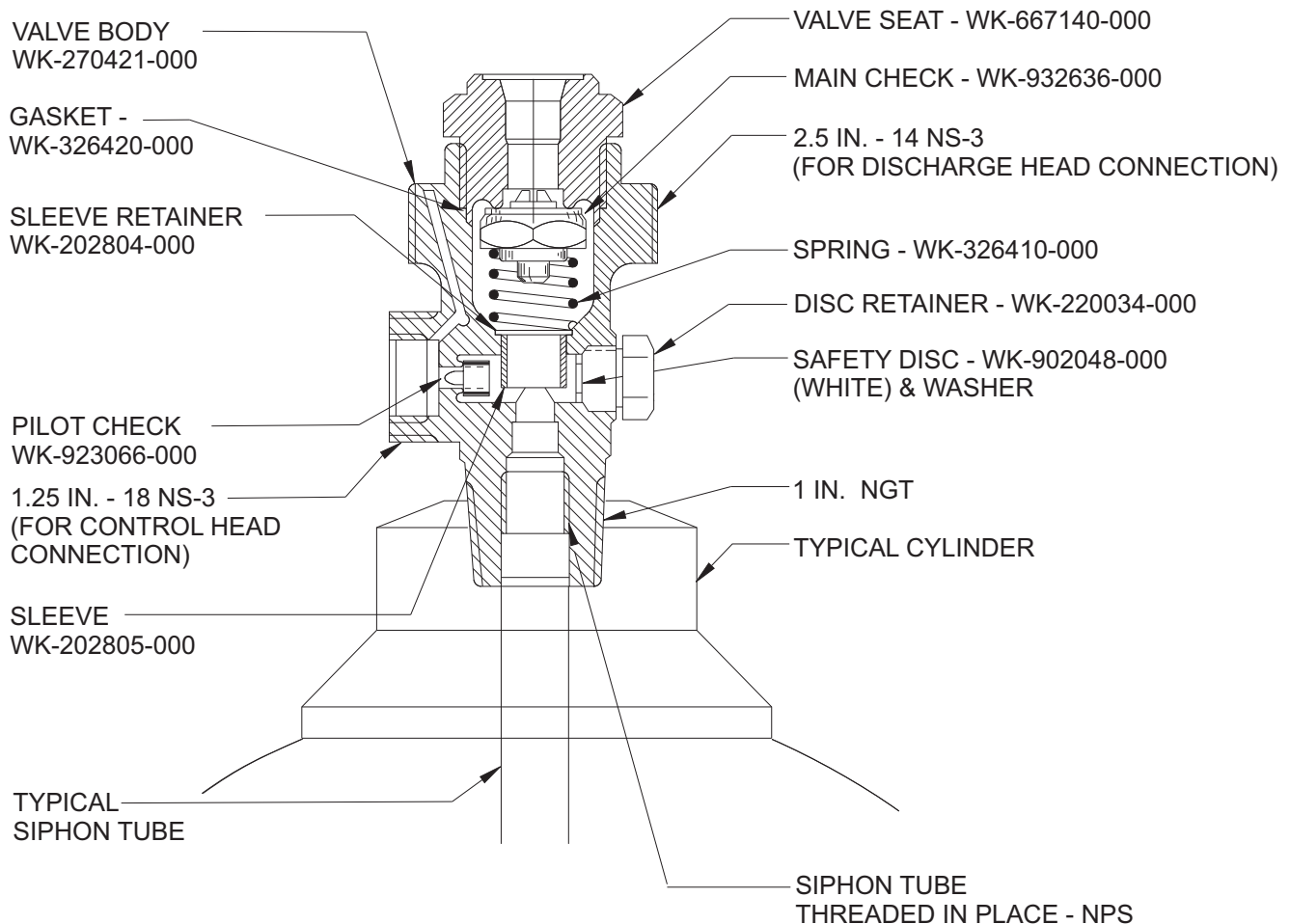

MATERIALS:

VALVE BODY:	BRASS
VALVE SEAT:	BRASS
SLEEVE:	BRASS
SLEEVE RETAINER:	BRASS
MAIN CHECK:	BRASS WITH RUBBER SEAT
PILOT CHECK:	STAINLESS STEEL WITH RUBBER SEAT

PRESSURE RATING:

WORKING = 2300 PSIG (158 BAR)

HYDROSTATIC = 6000 PSIG (413 BAR)

All trademarks are the property of their respective owners.

This literature is provided for informational purposes only. Kidde-Fenwal, Inc. assumes no responsibility for the product's suitability for a particular application. The product must be properly applied to work correctly. The technical data contained herein is limited strictly for informational purposes only. Kidde-Fenwal, Inc. believes this data to be accurate, but it is published and presented without any guarantee or warranty whatsoever. If you need more information on this product, or if you have a particular problem or question, contact Kidde-Fenwal, Inc.

©2016 Kidde-Fenwal, Inc.

EXPORT INFORMATION (USA)

Jurisdiction: EAR

Classification: EAR99

This document contains technical data subject to the EAR.

Kidde Fire Systems
400 Main Street
Ashland, MA 01721 USA
Ph: 508.881.2000
Fax: 508.881.8920
www.kiddefiresystems.com