

1. General

The HI-FOG water mist fire protection systems described in this data sheet are of the twin fluid, single-pipe type employing water as the suppressant and pressurized nitrogen as the propelling and atomizing media.

The MAU is a self contained unit and does not need any external water or electrical power. An electric signal is required to release the electric actuator valve if automatic or remote activation is used.

Each system arrangement is configured using a water and nitrogen supply to provide the total suppressant requirement for at least 10 min for the required amount of spray heads.

In a protected space, the forced ventilation, the flow of fuel and all non-essential lubrication and hydraulic fluids shall be terminated upon detection of a fire.

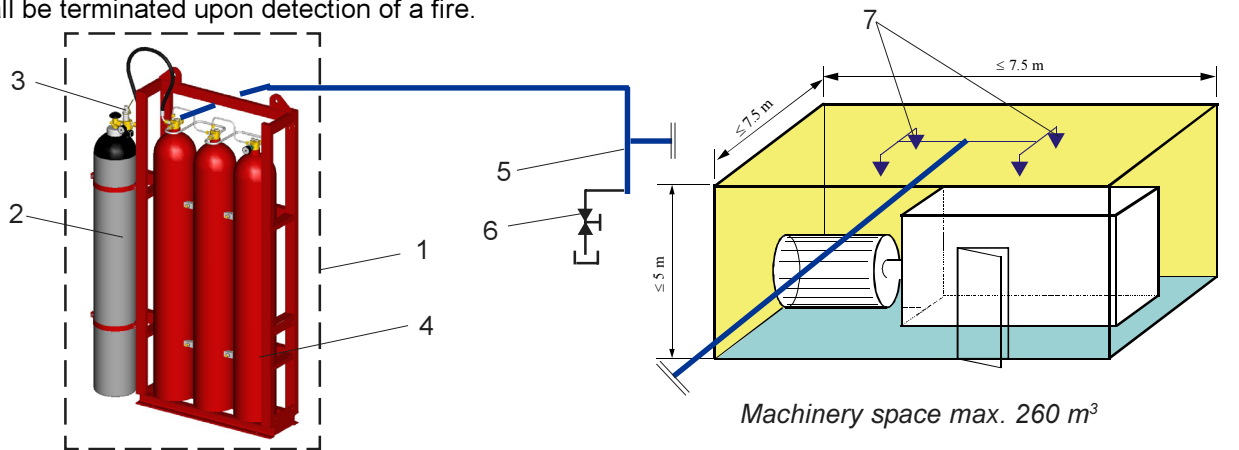

The basic MAU driven system consists of the following main components:

System description

- 1 Machinery space Accumulator Unit (MAU)
- 2 Pressurized nitrogen cylinder *)
- 3 Actuator valve on the gas cylinder
- 4 Water cylinder(s) with cylinder header(s)
- 5 Stainless steel piping
- 6 Drain/test valve (optional)
- 7 Spray heads

*) not included in Marioff supply

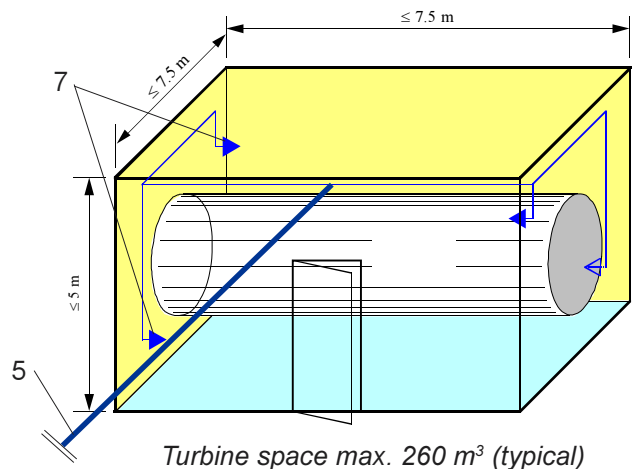

MAU (Machinery space Accumulator Unit) consists of water cylinders fully interconnected and powered by a pressurized nitrogen cylinder. In stand-by mode, the water cylinders and the piping system are not pressurized. Upon actuation the unit will discharge on a continuous basis for the duration of discharge through the stainless steel piping and the HI-FOG spray heads. The system activation can be done remotely or manually depending on the actuator valve. The system shall be interfaced with a suitable (approved) detection and control system capable of automatic operation.

Discharge types

Single Discharge comprises a single continuous discharge.

Extended Discharge comprises electrically timed or pneumatically sequenced discharges through a single distribution network. A typical application for this arrangement would be extended discharge to a gas turbine to accommodate coast down time. Commonly, extended discharge of 20 minutes of continuous protection is required for gas turbines. For VdS approved systems the required duration of discharge is 30 minutes, unless otherwise agreed.

Reserve system: reserve systems can be supplied according to the customer's specifications.



Total compartment protection of machinery spaces, turbine enclosures and special hazard machinery spaces with volumes up to and including 260 m³

Machinery space accumulator unit (MAU) system (FM & VdS approved)

28 Dec 2004

2. System approvals

Factory Mutual Approval Report, Project ID. J.I.0D5A4.AH, Class 5560, 9 Feb, 1998.



VdS Schadenverhütung GmbH approval, S 4040002, 16 February, 2004



3. System Applications

Typical applications include gas turbine enclosures and their auxiliary rooms, engine spaces and their auxiliary rooms, rooms for fuel or lubricating oil pumps, tanks or filtering systems, lubricating oil skids, gearboxes, generators, compressors, and transformers.

The applications are found in single cycle, combined cycle and cogen power generation facilities, in oil and gas production and transportation, various process industry facilities and in any area where hydrocarbon fuel powered machinery is operated.

Marioff Corporation will provide more information on a specific application upon request.

4. System requirements

Water used for the HI-FOG systems should be the equivalent of a potable supply. In all cases the fill line must be routed through a < 100 mm filter (supplied with the system), and the chloride concentration may not exceed 50 ppm (= 50 mg/l).

The system shall be stored and operated in the temperature range + 4 °C – + 54 °C. This may require customized heating or cooling facilities subject to the application and storage environment.

5. Wall openings and ventilations

Air flow in the enclosure shall be stopped upon detection of fire. Therefore, doors, all ventilation openings or forced ventilation arrangements shall be capable of automatic closure or shut-down prior to system discharge.

Fire tests have been passed with a normal size (0.8 m x 2 m) door open.

6. MAU unit dimensioning

Standard water storage/nitrogen configurations are as follows:

MAU-50	1 x 50 litre Water	+ 1 x 20 litre Nitrogen	up to 65 m ³	(10 min. discharge for 1 spray head)
MAU-100	2 x 50 litre Water	+ 1 x 50 litre Nitrogen	up to 130 m ³	(10 min. discharge for 2 spray heads)
MAU-150	3 x 50 litre Water	+ 1 x 50 litre Nitrogen	up to 260 m ³	(10 min. discharge for 4 spray heads)

The systems are suitable for operation by nitrogen storage cylinders of minimum 50 litre nominal capacity having nominal storage pressures in the range of 155 – 250 bar (@15°C). The proposed nitrogen operating pressure must be identified at the time of system order.

For further information and the space required for the MAU installation, see the corresponding Marioff MAU Technical Data Sheets.

7. Spray head

Spray head type: 4S 1MC 8MB 1100

The spray heads must be installed so that possible obstructions do not prevent effective water mist distribution.

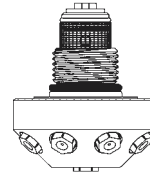

For further information, see Technical Data Sheet TC0220.

Gas turbine enclosures

Spray heads shall be wall mounted so that the water mist is discharged along the turbine in a path parallel to the centre line of the turbine. Horizontal mounting of spray heads within the turbine compartment prevents the direct impingement of water discharge onto the turbine casing. The spray heads should be positioned (min) 0.75 m and (max) 1.25 m from all walls perpendicular to end walls, i.e., side walls and ceiling and floor.

Gas turbine ancillary compartments: treat as machinery spaces

Machinery spaces

As applicable to enclosed spaces housing diesel engines, transformers, fuel and oil pumps, oil tanks, fuel filters, generators, gear boxes, drive shafts, lubricating oil skids, etc. Use spray heads located at ceiling level with downward projection at spacing of maximum 2.5 m distance from walls and at 2.5 m between spray heads. Alternatively the spray heads may be mounted horizontally as for gas turbines.

Special hazard machinery spaces: treat as for machinery spaces but add one spray head above service door.

8. Piping

The spray heads are coupled to purpose designed mounting adapters that are fitted at the time of the installation of the distribution network. Tube and fitting standards shall be in accordance with the recommendations of the most current edition of NFPA 750 and Marioff requirements.

The piping is made of corrosion resistant AISI 304 or 316 stainless steel (or equivalent), ensuring a long lifetime and clean water. The connections are usually ferrule type DIN 2353 joints or SAE 518J flange joints, which are type approved by classification societies. The couplings are made of stainless steel or brass, and are designed with a minimum safety factor of 4.

All system piping for pre-engineered systems up to 150 litres water storage shall comprise 16 mm O/D (1.5 mm wall) piping from the storage facility outlet to the first tee within the distribution pipe (12 mm up to MAU-100) and 12 mm O/D (1.5 mm wall) piping throughout thereafter. All individual branch piping to the spray heads shall be 12 mm. Note: This sizing is based on a maximum of five (5) spray heads with a single nitrogen cylinder. Marioff pre-engineered systems are intended to accommodate a maximum of 20 m of 12 mm piping within the protected risk for distribution and a maximum run of 10 m of 16 mm piping from the water storage facility outlet to the first T-piece within the protected space.

9. External connections

Electric

The 24 VDC / 1A electrical signal is required when an electrical actuator is used for system release. Also, the automatic fire detection system requires an electrical power supply.