

# Modular Sprinkler Pump Unit MSPU5

Product E012604

26 Sep 2008

## Description

The modular Sprinkler Pump Unit MSPU5 has an output flow of 487 lpm at 140 bar and is supplied as part of a VdS-approved HI-FOG® water mist fire protection system.

The MSPU5 comprises of five (3+2) pump modules which, upon activation, are started sequentially, thus reducing the electric power peak loads. In stand-by position, the system pressure is maintained at 25 bar by means of a stand-by pump. The MSPU5 can be started automatically, manually, or remotely. The automatic start is activated by flow or by low pressure, both of which are continuously monitored. The manual start is activated from the Starter Cabinet. The remote release can be included to allow activation by release panel or third-party signal.

The MSPU5 is stopped manually by pressing the STOP button on the Starter Cabinet after the section valve of the release area has been closed. Closing the section valve stops the water release and allows the pressure in the pipes to rise back to 140 bar. After the pressure is 140 bar, STOP and RESET functions can be completed.

## MSPU5 Starter Cabinet and Pump Unit

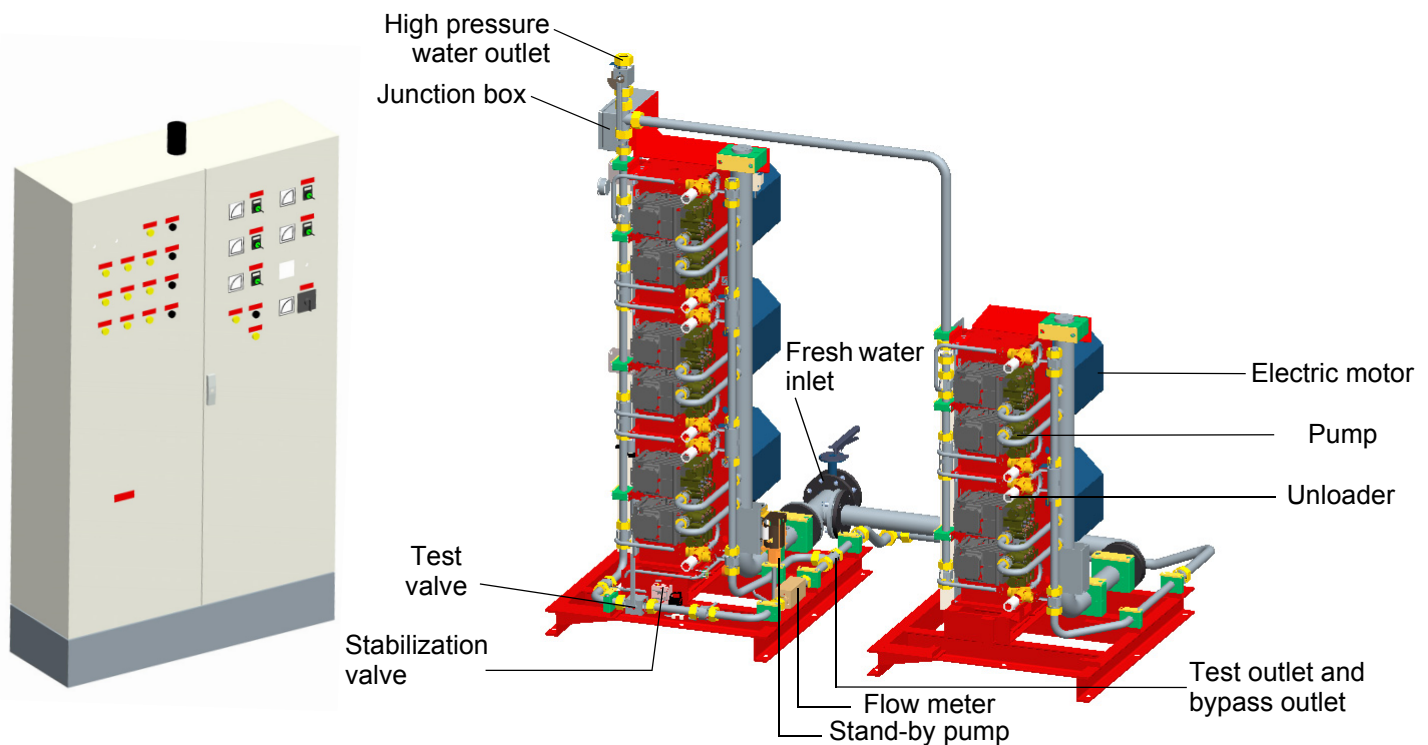

# Modular Sprinkler Pump Unit MSPU5

Product E012604

26 Sep 2008

Standard MSPU5 features	
max. output (lpm)	487
unit output pressure (bar)	140
stand-by pressure (bar)	25
dimensions l x w x h (mm)	1457 x 2160 x 2171
electric supply	400 V, 50 Hz, 135 kW, 400 A, TN-C/TN-S
electric motors	27 kW, 51 A, cast iron
dry mass (kg)	1870 (for cast iron electric motor)
air inlet type and dimension	BSP R1/4" female
fresh water inlet type and dimension	DN80 DIN2642 FLANGE
high pressure outlet type and dimension	∅ 38S DIN2353
test outlet type and dimension	∅ 38S DIN2353
Starter Cabinet enclosure class	IP54
Starter Cabinet dimensions w x d x h (mm)	1200 x 400 x 1800+200
Starter Cabinet mass (kg)	

## Special order options

- Water tank system
- Break water tank
- Pump unit filter SAE 2 1/2" connection kit
- External feed water pump
- External feed water pump starter in the Starter Cabinet
- Two electric supplies and automatic switchover function
- Supply voltage
- 60 Hz frequency
- Soft starters
- Aluminium motors
- Motor power 22,5 kW, 110/110 bar
- Connecting cables special lengths (15 m, 20 m)

## For more information

- MSPU5 Line Diagram & Part list for Line Diagram DHDUSP002303A
- Filter Unit Data Sheets TE9004 and TE9018
- Modular Tank Unit Data Sheet DOC0001724
- MSPU Operating and Maintenance Manual DOC0001718

# Modular Sprinkler Pump Unit MSPU5

Product E012604

26 Sep 2008

Pump Unit left side view

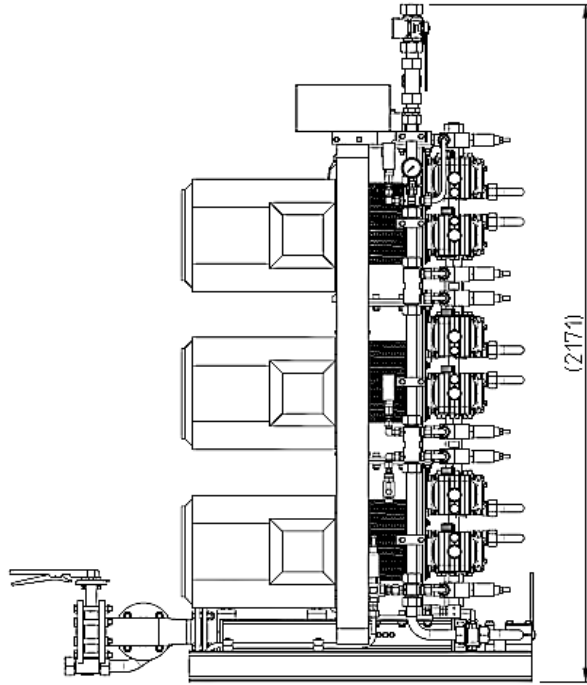

Motor view

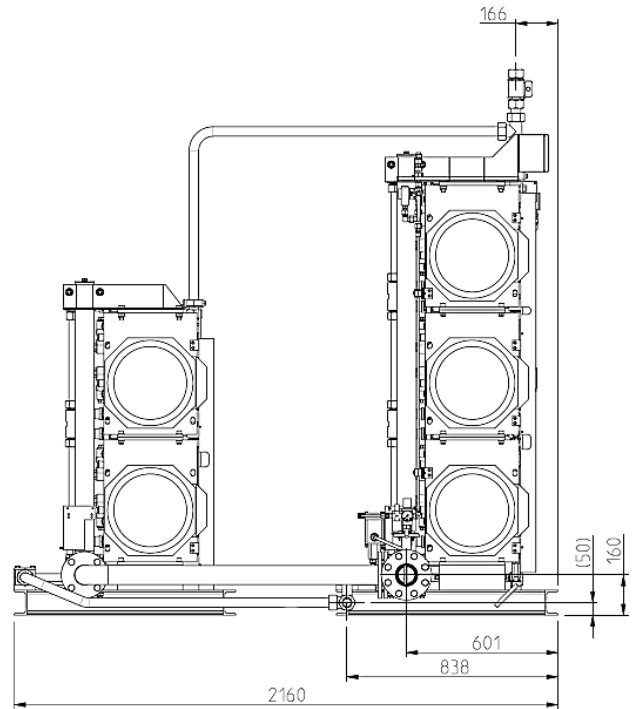

Pump Unit top view

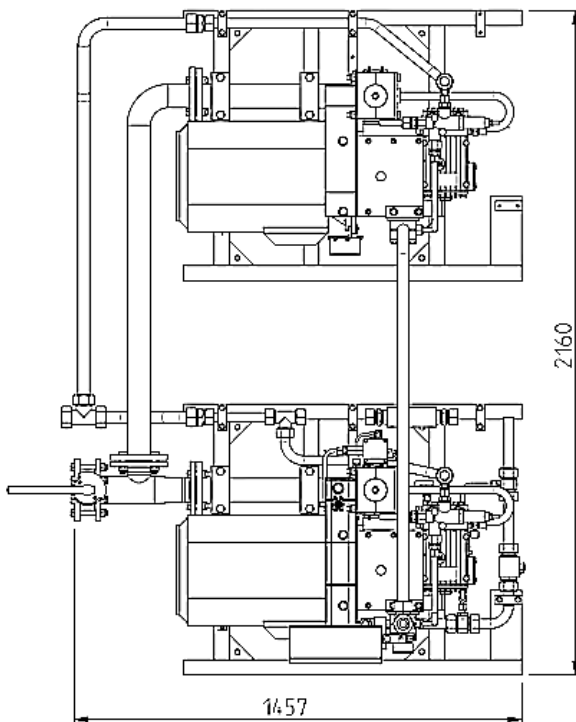

Pump view

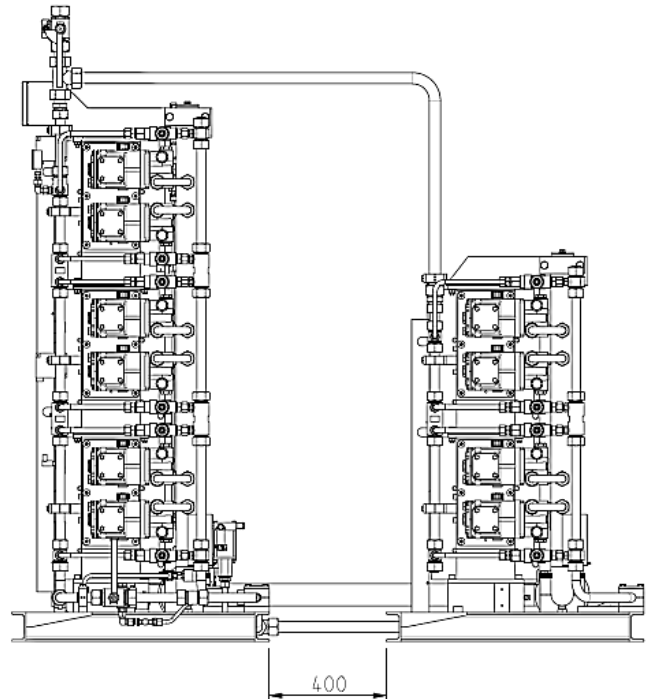

# Modular Sprinkler Pump Unit MSPU5

Product E012604

26 Sep 2008

## Starter Cabinet

The Starter Cabinet is used to monitor, operate, and control the MSPU5 pump unit. It indicates all operation and fault signals concerning the pump unit and the tank unit. The Starter Cabinet has the following manual operations and selections (numbers in brackets correspond those in the figure):

- Manual start motor 1–5 (M1–M5)
- Pump Unit manual start (1)
- Buzzer acknowledge (2)
- Alarm reset (3)
- Lamp test (4)
- Voltage metering selection (5)
- Pump Unit manual stop/system reset (6)

The MSPU5 has the following indications:

- 230VAC control voltage fault (7)
- Battery charger fault (8)
- Earth fault 24VDC (9)
- Pressure switch PS-1/PS-2 fault (10)
- Compressed air low pressure (11)
- Out of water (12)
- Sprinkler pump malfunction (13)
- Inlet/outlet valve closed (14)
- Circuit breaker released (15)
- Pump Unit motor overload (16)
- Control system on (17)
- Pump Unit deactivated (18)
- Motor M1.. M5 running
- Main supply on (optional)
- Emergency supply on (optional)

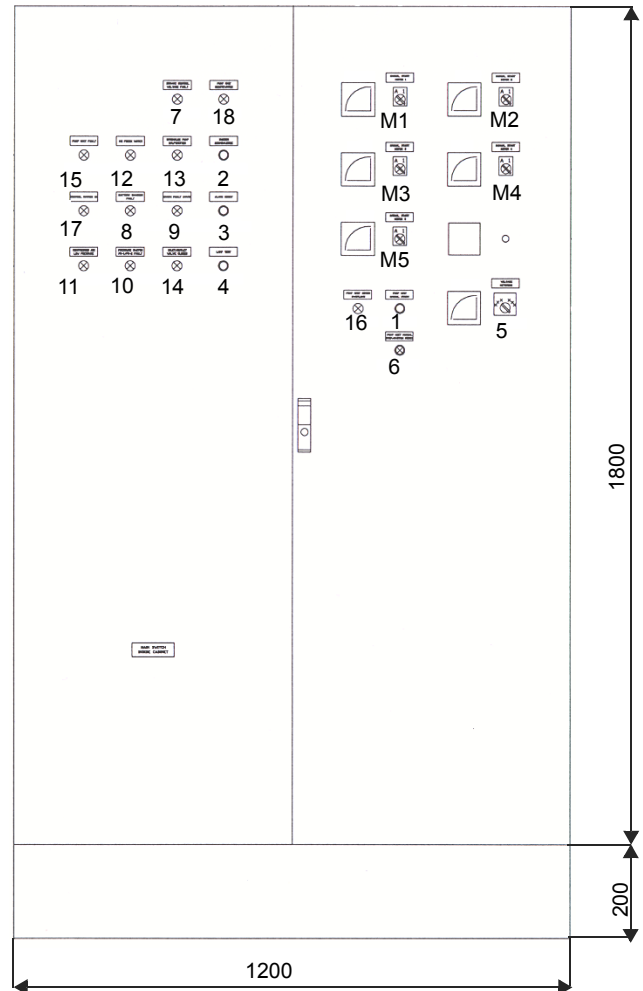

The MSPU5 has the following signals out for use by a third-party system:

- Out of water
- Sprinkler pump motor malfunction
- Pump unit fault
- 24VDC control system on/off
- Pump unit deactivated
- Pump unit running
- Stabilization on
- Pump unit flow

- Line voltage fault
- HI-FOG activated

Optional output signals (instead of Line voltage fault):

- Main power supply fault
- Emergency power supply fault