

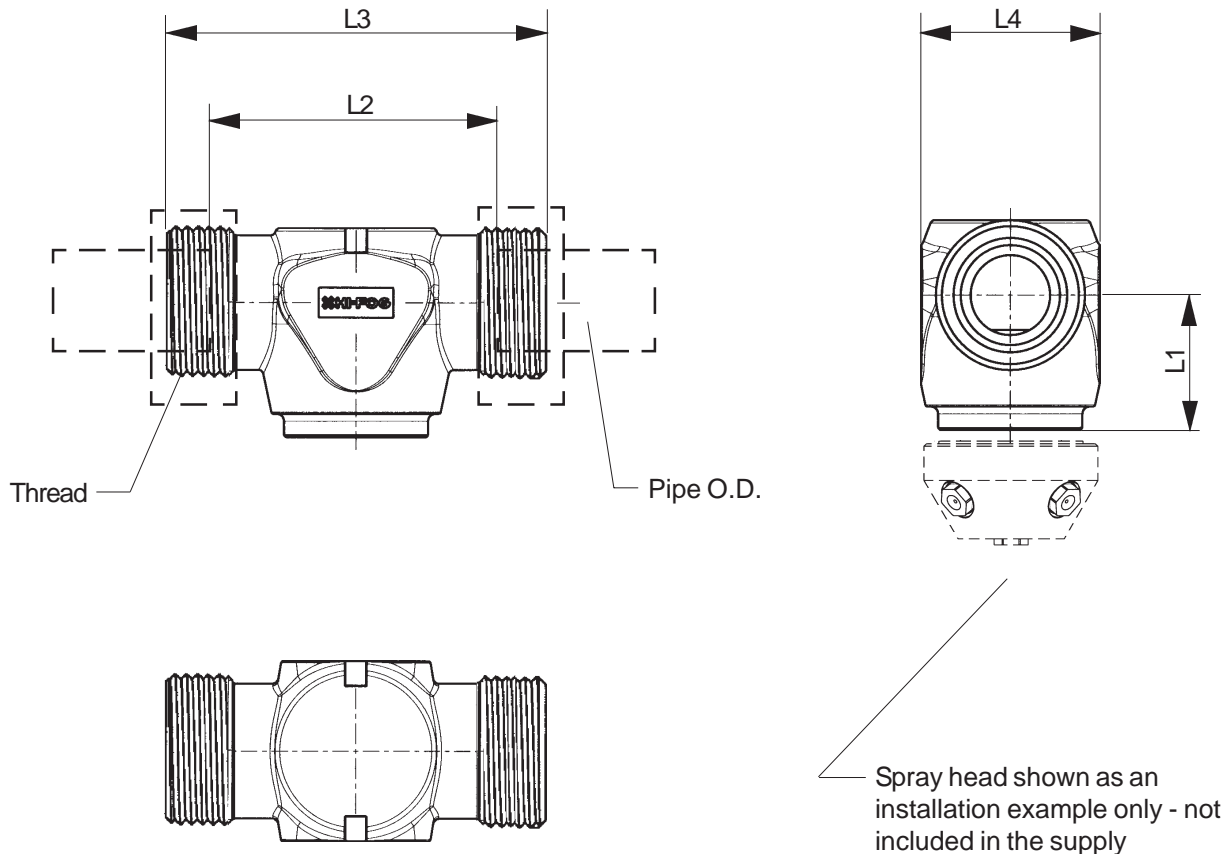

Product	Pipe O.D.	Body mass	L1	L2	L3	L4	Thread
C43072.1	12	0,19 kg	27	49	64	27	M20x1,5
C43073.1	16	0,23 kg	29	51	68	27	M24x1,5
C43070.1	20	0,37 kg	29	57	78	36	M30x2
C43075.1	25	0,45 kg	29	60	84	36	M36x2
C43080.1	30	0,57 kg	31	61	88	41	M42x2





General	<p>Body material cast stainless steel (CF8M).</p> <p>Assembly bodies for 1000 and 2000 series sprinklers. The assembly bodies do not include check valves which means that the sprinklers can not be detached from the bodies without depressurizing the pipes first.</p>	
Connection	Thread for cutting ring connection DIN2353	
Installation	Location	Ceiling or wall, surface mounted
	Projection	Pendent or horizontal
Installation example (C43070.1)		