

Stock code	Type	Note
D82005	DA B P T190 N A/B 10	with pressure switch
D82015	DA B P N N A/B 10	no pressure switch

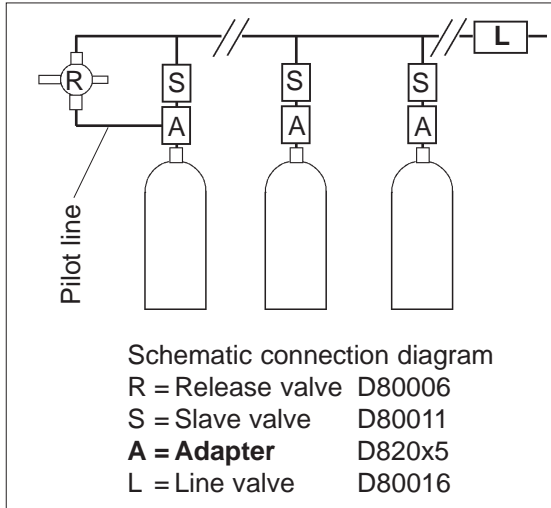

Pressure gauge/switch (D82005)
 or
 gauge (D82015)

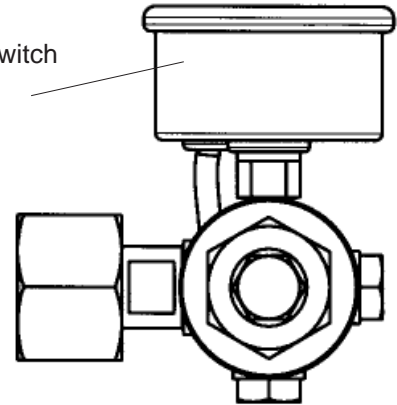

	D82005	D82015
A	87 mm	80 mm
B	83 mm	78 mm
C	57 mm	52 mm

Inlet from gas cylinder
 Thread 24,32 x 1,814 SFS2292

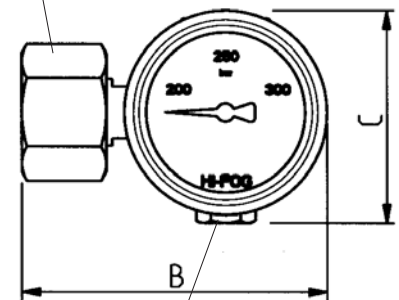
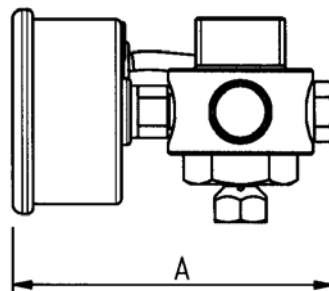

Pilot line connection R 1/8" (when needed - plugged in drawing)

General	Body material	Brass
	Mass	D82005: 0,61 kg D82015: 0,53 kg
	Max. working pressure	200 bar
Installation	Connections	Threads 24,32 x 1,814 SFS2292
Operation	The gas valve adapter connects the gas cylinder to a slave valve, a delta-P valve or equal The gas valve adapter is equipped with a pressure gauge and a pressure switch (D82005 only) for monitoring purposes.	