

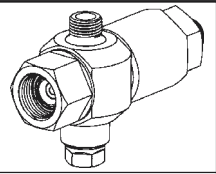

HI-FOG®

Technical Data Sheet TD8020

Delta P Valve DG DP 15/200 B 8S P 10



Stock code D80022.A

TA

17 May 2005

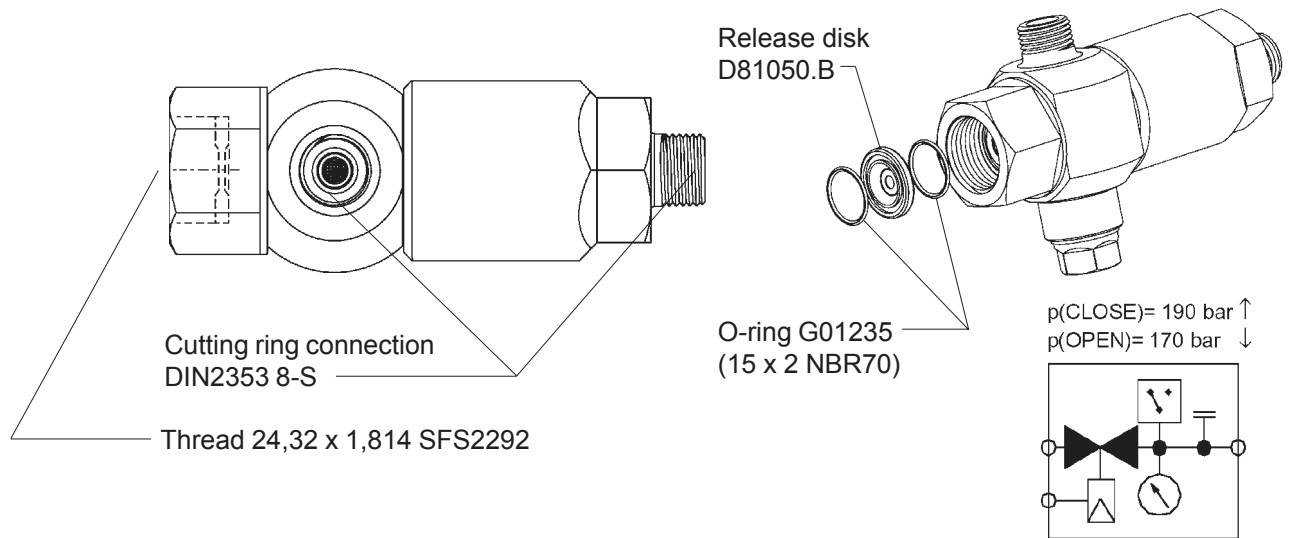
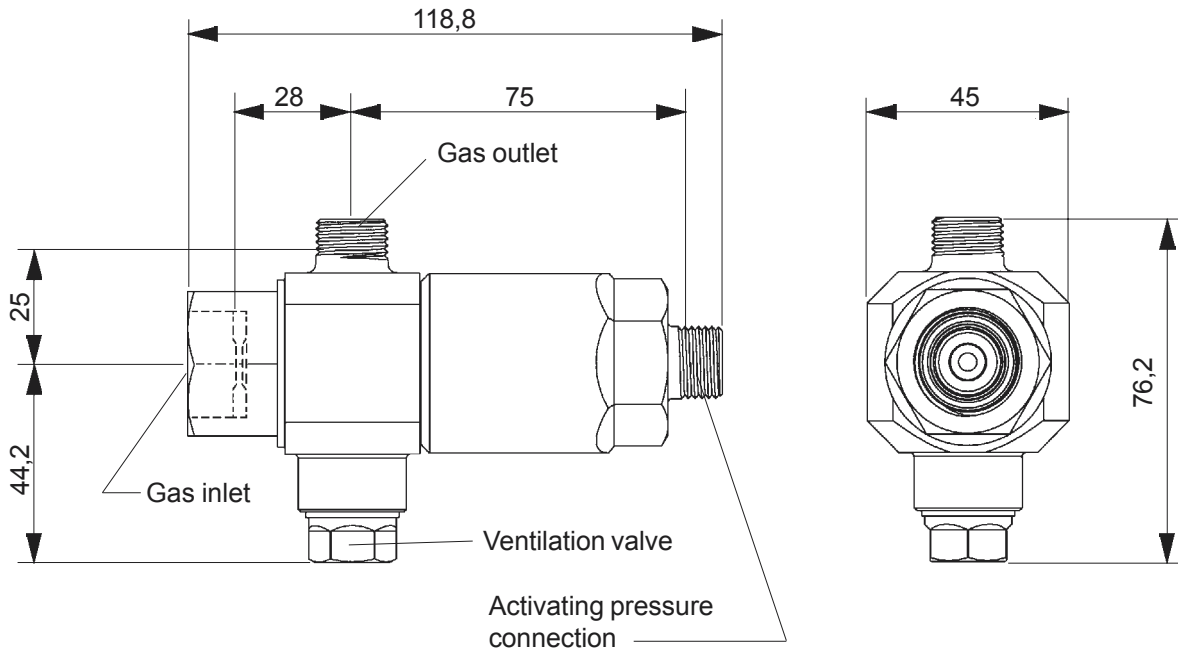

General	Body material	Brass, nickel plated
	Mass	1,0 kg
	Release pressure	15 - 25 bar
	Max. working pressure	200 bar
Operation	<p>The ΔP valve is used to release additional gas cylinder(s) in a system in a predefined sequence. The ΔP valve is activated when the previous shot is released, but the gas flow through the valve is delayed until the pressure in system piping has dropped to 15 - 25 bar.</p> <p>The release of the ΔP valve may be used to release slave valves. Note: line valve needed for slave valves</p> <p>The valve is reset by replacing the release disk.</p>	

Marioff Marioff Corporation Oy, P.O. Box 86, Virnatie 3, FIN-01301 Vantaa, Finland,
 tel +358 9 870 851, fax +358 9 8708 5399, e-mail info@marioff.fi, www.hi-fog.com