

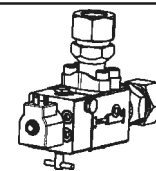

Machinery Space Valve NS 20



Stock codes D00052.1 & D00073

TA 30 Aug 2004

Stock code	Valve type	Voltage	Water tube O.D. [mm]	
			Inlet	Outlet
D00052.1	SVM 20-A2N-S30/30-10-M	24 VDC	30,0	30,0
D00073	SVM 20-B2N-S30/30-10-M	230 VAC	30,0	30,0

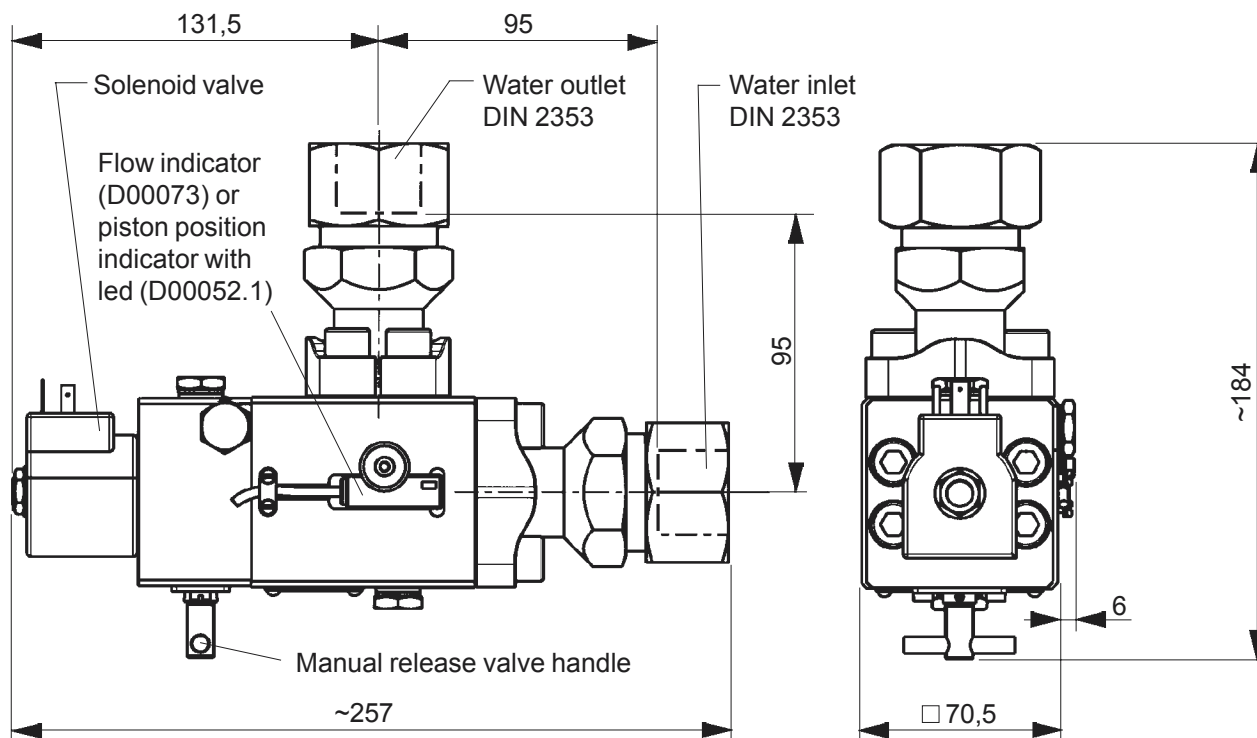

Description:

Machinery space valve is used to control the spray head system activation. In the case of fire, the machinery space valve is opened by the remote operated solenoid or by opening the manual release valve. In both cases, the flow through the section valve is detected by the flow indicator (in valve D00073) or by the piston position indicator (in valve D00052.1), which will send a signal to the control board, identifying the opened machinery valve.

In order to open the machinery valve, either the solenoid or the manual release valve can be used. To close the machinery valve, it is essential to ensure that both the solenoid and the manual release valves are closed as they operate the machinery valve independently. After closing the machinery space valve, a small leakage may occur as the pressure is stabilizing.

In valve D00052,1 the piston position indicator led shows the piston position inside the valve: led light on = piston in stand by position; led light off = piston in open position.

General	Body material	Brass
	Connections	Cutting ring DIN2353
	Valve function	Normally closed
	Solenoid function	-10: closed when electric circuit to solenoid valve is open
	Mass (all versions)	~7 kg
	Max. pressure	200 bar