

Stock code	Valve type	A [mm]	B [mm]	C [mm]	D [mm]	Water pipe O.D. [mm]	
						Inlet	Outlet
D06151	SBA 40-A3P-S30/30-10-A	135	104	~327	~253	30,0	30,0
D06161	SBA 40-A3P-S38/30-10-A	148	104	~339	~253	38,0	30,0
D06171	SBA 40-A3P-S38/38-10-A	148	117	~339	~265	38,0	38,0

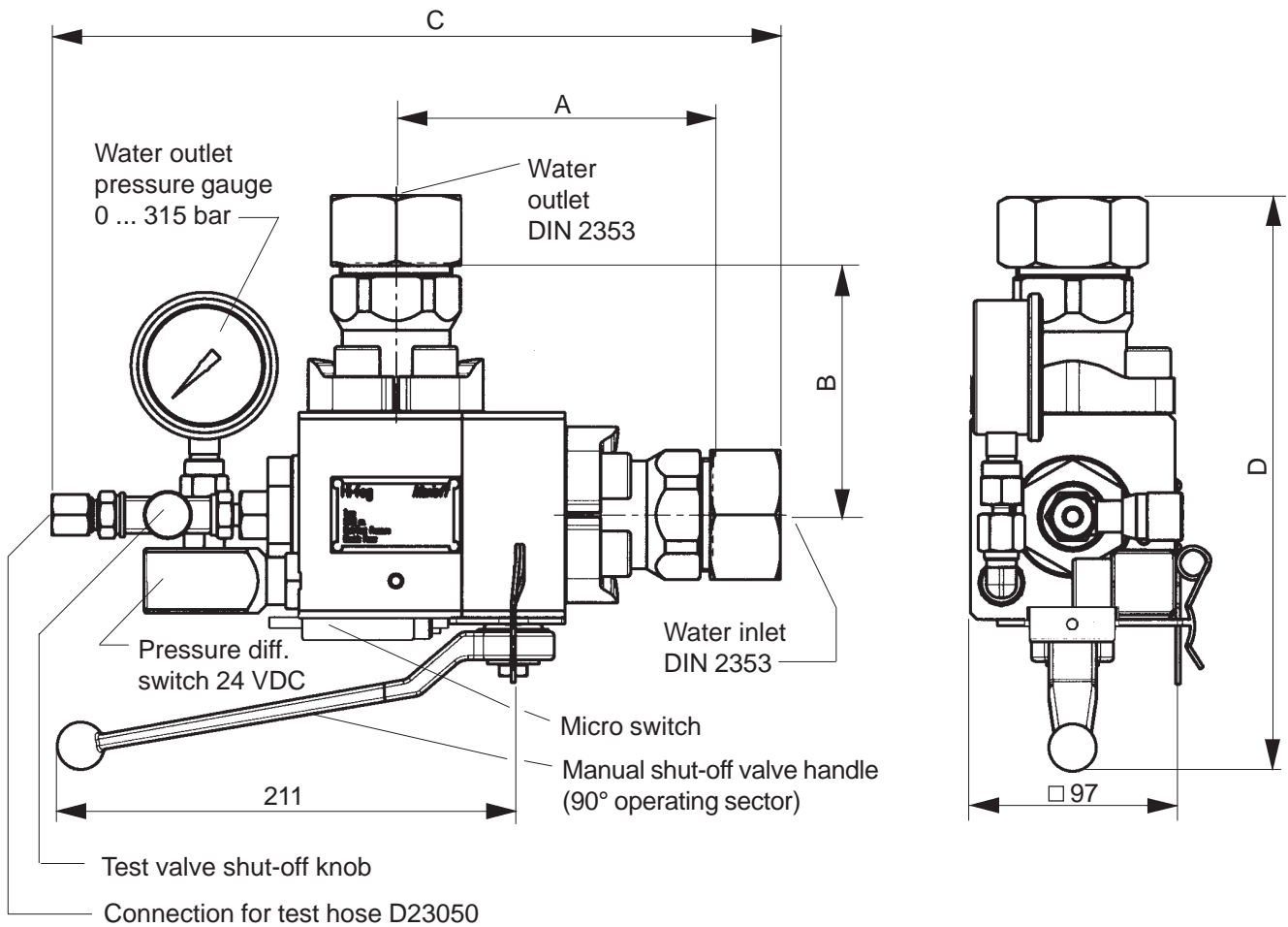

Description:

The section ball valve is used to divide the sprinkler system into different sections. In the case of fire the sprinkler activates, causing flow through the valve. The flow is detected by the pressure difference switch, which sends a signal to the control board, identifying the activated section.

The section ball valve is normally open, but can be closed with the manual shut-off valve. Manual shut-off valve handle position is detected by the micro switch.

The test connection is used to test the flow monitor function, by causing a flow through the valve.

General	Body material	Brass
	Connections	Cutting ring DIN2353
	Valve function	Normally open, with manual shut-off valve
	Mass (all versions):	
	Max. working pressure	140 bar