

Note: Spare part kit V21013 consists of:

Item	Stock code	Qty
Release disk	D81050.B	1 pc
O-ring (15 x 2 NBR70)	G01235	2 pcs

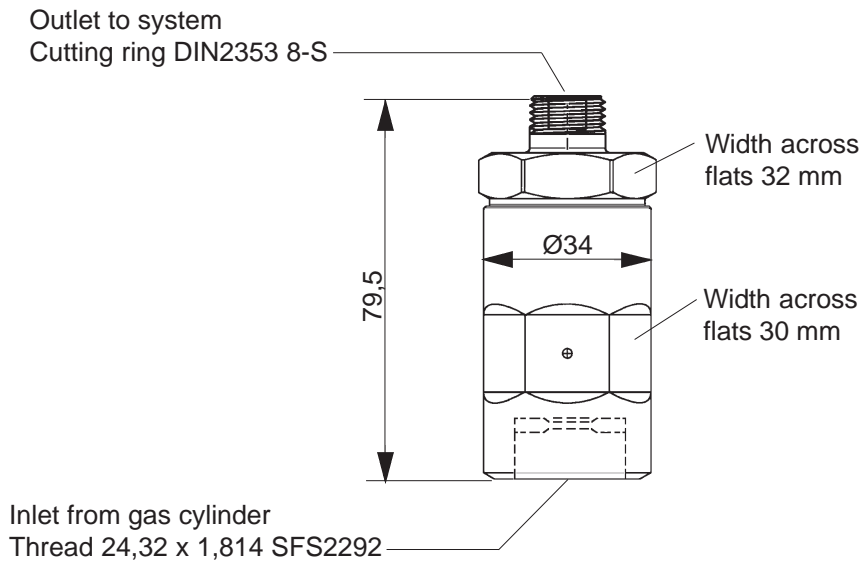
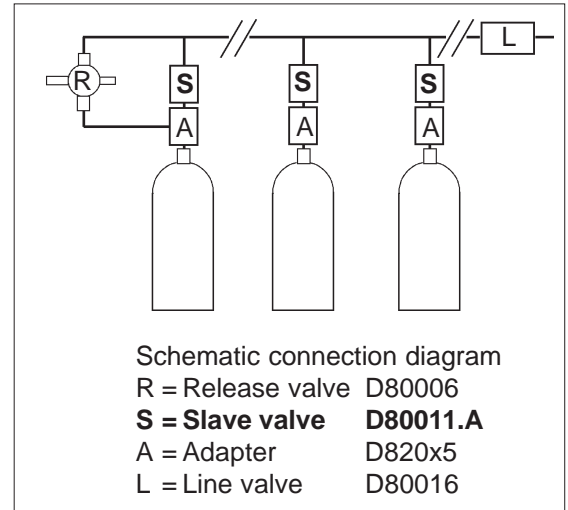

<b>General</b>	Body material	Brass, nickel plated
	Mass	0,54 kg
	Release pressure	max. 45 bar
	Max. working pressure	200 bar
<b>Operation</b>	The slave valve releases the gas from the cylinder into the system when the pressure rises above 50 bar in the pipework. To insure the pressure rise a line valve is to be used. The valve is reset by replacing the release disk.	