

Kidde Engineered Fire Suppression System

Designed for use with 3M™ Novec™ 1230 Fire Protection Fluid



A UTC Fire & Security Company

Effective: March 2007
K-45-9060

Lever and Lever/Pressure Operated Control Heads

FEATURES

- *UL Listed, ULC Listed, FM Approved*
- *P/N 870652 (Lever Operated Control Head)*
- *P/N 878751 (Lever/Pressure Operated Control Head)*

P/Ns: 870652 AND 878751

DESCRIPTION

The lever-operated control head is used for manually actuated Kidde Engineered Fire Suppression Systems designed for use with 3M™ Novec™ 1230 Fire Protection Fluid, consisting of one or two cylinders. It is also used as a secondary source of actuation, as an emergency manual release device for pressure-operated control heads and in conjunction with components such as pressure operated time delays, stop valves and directional valves.

The control head is equipped with an operating lever secured in the closed position by a safety pull pin and seal wire. To activate the control head, the lever is rotated to the open position by removing the safety pin. This will discharge a cylinder, bypass a time-delay period or open a directional valve.

The lever/pressure-operated control head consists of a spring-loaded piston-and-stem assembly that is housed in a brass body, and a lever for emergency manual operation. The body has a threaded inlet port that connects to the pressure line and a swivel nut for connection to a control port. The pressure from the agent actuates the spring-loaded piston-and-stem assembly to engage the pilot check of the control port to which it is connected. This can also be achieved through manual operation of the lever.

INSTALLATION



Before installing any control head on a cylinder valve, ensure that the control head is in the "SET" position (actuating pin is in the fully retracted or "SET" position). Failure to position control head in the "SET" position will result in accidental cylinder discharge would could cause severe injury.

LEVER OPERATED CONTROL HEAD

1. Ensure control head is in the "SET" position with locking pin and seal wire intact.
2. Remove protection cap from cylinder valve or stop valve pilot control port.

3. Using a suitable wrench, assemble control head to cylinder valve or stop valve pilot control port. Tighten swivel nut securely.



LEVER/PRESSURE OPERATED CONTROL HEAD

1. Ensure control head is in the "SET" position with locking pin and seal wire intact.
2. Remove protection cap from cylinder valve or stop valve pilot control port.
3. Connect flexible actuation hose to pressure operated control head.
4. Using a suitable wrench, assemble control head to cylinder valve or stop valve pilot control port. Tighten swivel nut securely.

MAINTENANCE MONTHLY

Inspect control heads that are attached to suppression cylinders, nitrogen cylinders, stop valves and time delays for any physical damage, deterioration, corrosion, dirt and loose couplings. Tighten any loose couplings. Replace the control head if damage is found. If necessary, clean as directed in the Design, Installation, Operation and Maintenance Manual (P/N 45-N1230M-001). Ensure that all control heads and actuation devices, etc.,

are all in the "SET" or "closed" position with the locking pin installed and seal wire intact.

SPECIFICATIONS

Materials:

Body: Brass
Lever: Stainless Steel

Weight: 1.1 lb. (0.5 kg)

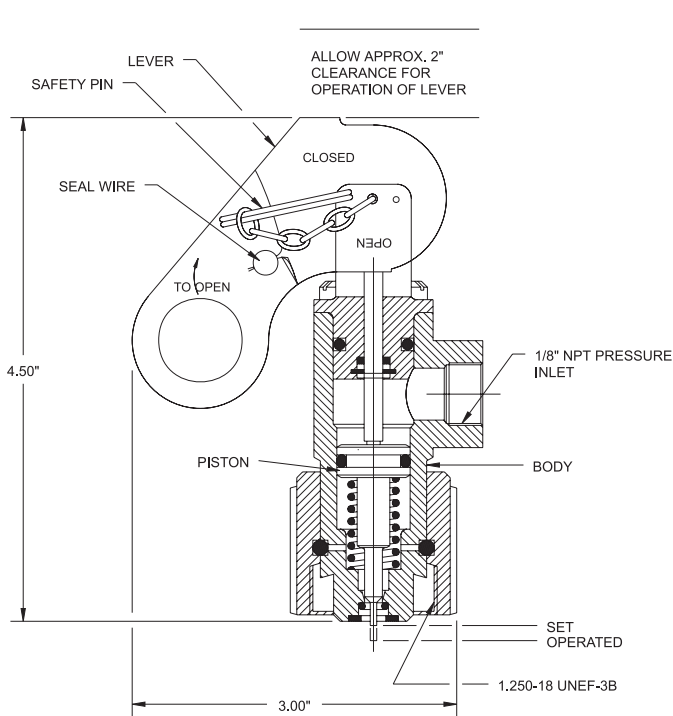

Figure 1. Lever/Pressure Operated Control Head

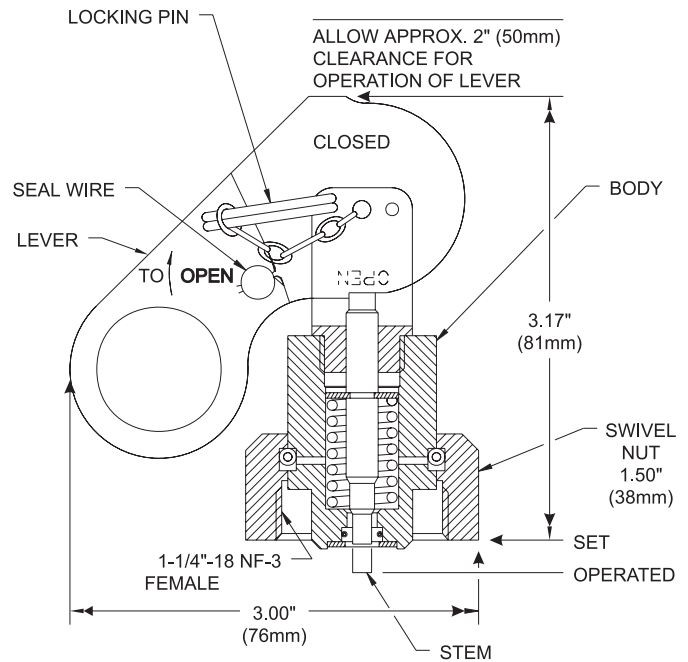

Figure 2. Lever Operated Control Head

Kidde is a registered trademark of Kidde-Fenwal, Inc.
3M and Novec are trademarks of 3M.
All other trademarks are property of their respective owners.

This literature is provided for informational purposes only. KIDDE-FENWAL, INC. assumes no responsibility for the product's suitability for a particular application. The product must be properly applied to work correctly. If you need more information on this product, or if you have a particular problem or question, contact KIDDE-FENWAL, INC., Ashland, MA 01721. Telephone: (508) 881-2000.