

Kidde Engineered Fire Suppression System

Designed for use with 3M™ Novec™ 1230 Fire Protection Fluid



Effective: June 2015
K-45-9042

2-inch Swing Check Valve

FEATURES

- *Low Equivalent Length*
- *For Use with Multiple Cylinder Manifolds and Main/ Reserve Systems*
- *UL Listed, ULC Listed, and FM Approved for use with Novec 1230 Systems*

P/N: 06-118213-001

DESCRIPTION

The 2-inch Swing Check Valve is installed at each container (10 through 350 lb. container size) in a multiple cylinder container system to permit removal of containers while maintaining a closed system. The check valve may also be installed in main and reserve system configurations. Inlet and outlet connections are 2-inch female NPT. The check valve can be mounted in an upright horizontal orientation or a vertical orientation with the outlet at the top.

OPERATION

In the case of multiple cylinder installations, the check valve prevents back flow from the manifold in the event that the system is discharged when one or more cylinders are disconnected, such as when weighing or during general servicing. In the case of the check valve being used in a main and reserve configuration, it prevents the actuation of the reserve system from manifold pressure.

INSTALLATION

The check valve can be installed between zero and ninety degrees from the horizontal. The check valve must be installed so that the arrow is pointing in the required direction of flow.

ORDERING INFORMATION

The part number for ordering the 2-inch swing check valve is 06-118213-001.

SPECIFICATIONS

Valve body and cover: Bronze
Service pressure: 600 PSI



DIMENSIONS

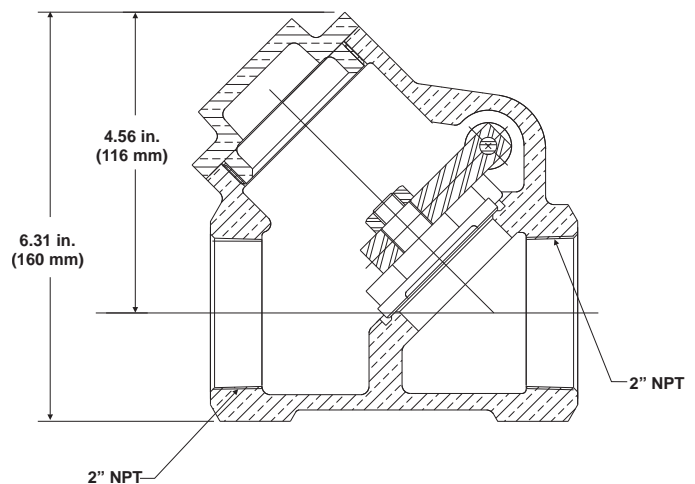

Kidde is a registered trademark of Kidde-Fenwal, Inc.
3M and Novec are trademarks of 3M.
All other trademarks are property of their respective owners.

This literature is provided for informational purposes only. KIDDE-FENWAL, INC. assumes no responsibility for the product's suitability for a particular application. The product must be properly applied to work correctly.
If you need more information on this product, or if you have a particular problem or question, contact KIDDE-FENWAL, INC., Ashland, MA 01721. Telephone: (508) 881-2000.

Kidde Fire Systems
400 Main Street
Ashland, MA 01721
Ph: 508.881.2000
Fax: 508.881.8920

www.kiddefiresystems.com