

Kidde ECS 500 psi with FK-5-1-12 Fire Protection Fluid



Effective: January 2018

K-45-0507

Cylinder and Valve Assemblies, 1100 lb. Capacity Cylinder Data Sheet

FEATURES

- Large Capacity Cylinder
 - 3-inch Discharge Valve
 - Liquid Level Indicator
 - Optional Supervisory Low Pressure Switches
 - UL Listed, ULC Listed, and FM Approved for use with Kidde ECS 500 psi Systems
 - DOT and TC Approved
-

DESCRIPTION

Kidde Fire Systems ECS 500 psi Fire Suppression System 1100 lb. cylinders store FK-5-1-12 super-pressurized with dry nitrogen to 500 PSIG at 70°F (3.45 MPa at 21°C). The cylinders are painted red and are equipped with a 3-inch pressure differential valve, pressure gauge, liquid level indicator and optional low-pressure switch assembly. The safety burst disc is located on the cylinder head.

OPERATION

The agent storage container discharges when the actuation assembly operates, causing the pressure differential valve to open. All of the Kidde actuators may be used to actuate the 1100 lb. cylinder. The only exception is the P/N 82-486500-010, which is not compatible with the 3" cylinder valve.

INSTALLATION

The container is installed in a vertical position with the valve assembly pointing up. Interconnection to discharge piping is 3-inch NPT. Interconnection can be via a 3-inch flex hose (P/N 06-118225-001) or via a suitably pressure rated groove style fitting.

The container is secured in place by a mounting strap (P/N 30710193), which must be fixed to a solid wall or strut assembly. After the container is securely mounted, it is connected to discharge piping per the directions in the Design, Installation, Operation and Maintenance Manual (P/N 06-237585-001).

An optional cylinder supervisory pressure switch (P/N 45-118500-001 or 45-500537-001) can be installed on the cylinder valve in the field if required. This cylinder supervisory pressure switch has a 1/4 inch SAE flared connection.

ORDER INFORMATION

The part number for ordering the Kidde Fire Systems ECS 500 psi Fire Suppression System 1100 lb.cylinder with liquid level indicator is 45-551101-001.



MAINTENANCE

According to NFPA standards the following inspection and/or maintenance procedure must be scheduled as listed below and performed upon the occurrence of any event which might affect the reliability of the system.

QUARTERLY INSPECTION

1. Check the pressure gauges of each agent storage container. If the pressure gauge indicates a loss in pressure of 10% or more, then it shall be recharged or replaced. Pressure varies with temperature, and this must be taken into account when checking the pressure gauge.
2. Check all components, including supporting hardware, and tighten, repair or replace as required.
3. Replace any component if at all in doubt of its ability to perform properly.

SEMI-ANNUAL INSPECTION

Qualified personnel are to determine the amount of agent in all containers. The optional liquid level indicator may be used to measure agent supply and compare it to the original net weight which is marked on the container label. If the measured net weight is less than 95% of the original charged weight the container should be recharged or replaced.

Inspect all piping, fittings and nozzles for looseness, dirt or other damage. All outlet piping must be clean and free of dirt, chips, fillings and other foreign material that may cause the system to become inoperative or ineffective at the time of discharge.

SPECIFICATIONS

Fill Range	550-1099 lb. (249.5-498.5 kg)
Height	59.5 in (1511 mm)
Diameter	30 in (762 mm)
Internal Volume	15.7ft ³ (.444 m ³)
Empty Weight	653 lb (296 kg)
Temperature Range	32 to 130°F (0 to 54°C)
Safety Relief Burst Range	800 to 975 psi (5.5 to 6.7 MPa)
Construction Specification	DOT 4BW-500

DIMENSIONS

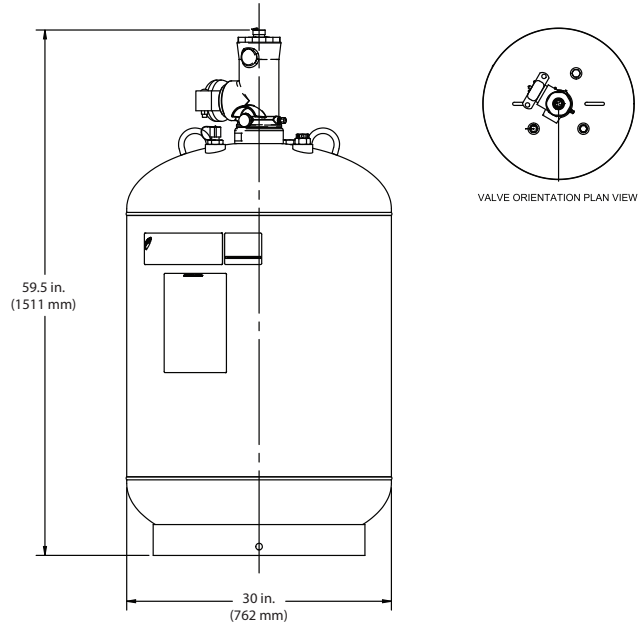

ACCESSORIES

Description	Part Number
3-inch stainless steel flexible hose	06-118225-001
3-inch swing check valve	06-118058-001
3-inch straight check valve	85-679330-001
Cylinder mounting strap	30710193
Cylinder supervisory pressure switch	45-118500-001
Cylinder supervisory pressure switch (ATEX)	45-500537-001

EXPORT INFORMATION (USA)

Jurisdiction: EAR
Classification: EAR99

This document contains technical data subject to the EAR.

All trademarks are the property of their respective owners.

This literature is provided for informational purposes only. KIDDE-FENWAL, INC. believes this data to be accurate, but it is published and presented without any guarantee or warranty whatsoever. KIDDE-FENWAL, INC. assumes no responsibility for the product's suitability for a particular application. The fire suppression system design, installation, maintenance, service and troubleshooting must be performed by trained, authorized Kidde Fire Systems distributors for the product to work correctly. If you need more information on this product, or if you have a particular problem or question, contact: KIDDE-FENWAL, INC., Ashland, MA 01721 USA, Telephone: (508) 881-2000.

